

WATSON 5

LTU / NTU

Operating Manual

<i>Document Identification</i>	SZ-DOC-W5-1.doc
<i>Document Version</i>	1.5
<i>Document Revision</i>	2002-10-15

Version Control

<i>Version of Operating Manual</i>	<i>Major changes to previous version</i>
1.0	Initial version, LSs
1.1	Added description for "Remote Firmware Download Procedure" Added new Monitor commands STARTBER, STOPBER, READBER, RESETBER
1.2	Description for ALARM HISTORY, POWER BACKOFF and CLOCK POLARITY commands added, URr
1.3	New commands added according to Firmware Version 1.4, TS, DIAGNOSTIC, etc, GWp
1.4	Minirack Version erased, Minirack Mechanics added, GWp
1.5	PID change, DIA display changed, 3p,4p operation added, Mode 3,4 added, format adaptations, GWp

Copyright 2002 by Schmid Telecommunication, Zurich, Switzerland. All rights reserved. Reproduction of part or all of the contents in any form is expressly prohibited without the prior written consent of Schmid Telecommunication.

Schmid Telecommunication has used its discretion, best judgments and efforts in preparing this document. Any information contained in this document is provided without any warranty of any kind. Schmid Telecommunication hereby disclaims any liability to any person for any kind of damage. Schmid Telecommunication may make improvements and/or changes of this document at any time.

Declaration of Conformity Watson 5

		Tabletop
	W5 NTU E1/PRA/1200hm, single link 1p	SZ.886.V310
	W5 NTU E1/1200hm & nx64, single link 1p	SZ.886.V318
	W5 NTU E1/PRA/750hm, single link 1p	SZ.886.V330
	W5 NTU E1/750hm & nx64, single link 1p	SZ.886.V338
	W5 NTU nx64, single link 1p	SZ.886.V380
	W5 NTU E1/PRA/1200hm, single link 2p	SZ.886.V410
	W5 NTU E1/PRA/1200hm & nx64, single link 2p	SZ.886.V418
	W5 NTU E1/PRA/750hm, single link 2p	SZ.886.V430
	W5 NTU E1/PRA/750hm & nx64, single link 2p	SZ.886.V438
	W5 NTU nx64, single link 2p	SZ.886.V480
	W5 NTU E1/PRA/120 Ohm, single link 4p	SZ.886.V810
	W5 NTU E1/PRA/75 Ohm, single link 4p	SZ.886.V830
	W5 NTU nx64, single link 4p	SZ.886.v880
	19" Minirack Mechanics for Table Top	SZ.896.V100
		Plug-in with 19" subrack SZ.379.V3
	W5 LTU E1/1200hm & nx64, single link 1p	SZ.866.V318
	W5 LTU E1/750hm & nx64, single link 1p	SZ.866.V338
	W5 LTU E1/1200hm & nx64, single link 2p	SZ.866.V418
	W5 LTU E1/750hm & nx64, single link 2p	SZ.866.V438
	W5 LTU 2*E1/1200hm, dual link 1p	SZ.866.V511
	W5 LTU 2*E1/750hm, dual link 1p	SZ.866.V533
	W5 LTU 2*nx64, dual link 1p	SZ.866.V588
	W5 LTU 2*E1/1200hm, dual link 2p	SZ.866.V711
	W5 LTU 2*E1/750hm, dual link 2p	SZ.866.V733
	W5 LTU 2*nx64, dual link 2p	SZ.866.V788
	W5 LTU 2*E1/1200hm, quad link 1p, MP	SZ.866.V611
	W5 LTU 2*E1/750hm, quad link 1p, MP	SZ.866.V633
	19" Minirack Mechanics for Plug-In	SZ.876.V100

Manufacturer:

Schmid Telecom AG, Binzstrasse 35, CH-8045 Zurich

The products mentioned above comply with the regulations of the following European Directives:

<p>89/336/EEC Directive containing requirements in respect with electromagnetic compatibility.</p>	<p>The compliance of the above mentioned product with the requirements of the directive 89/336/EEC is ensured by complete application of the following harmonized European Standards: <i>EN 300386:2000</i></p>
<p>73/23/EEC Directive containing requirements in respect with safety requirements.</p>	<p>The compliance of the above mentioned product with the requirements of the directive 73/23/EEC is ensured by complete application of the following harmonized European Standards:</p>

99/5/EEC

Directive containing requirements in respect with
Radio & Telecommunication Terminal Equipment.

EN 60950:2000 (IEC 60950:1999)

The compliance of the above mentioned product with the requirements of
the directive 99/5/EEC is ensured by complete application of the following
harmonized European Standards:

EN 55022:1998, EN 55024:1998

EN 60950:2000 (IEC 60950:1999)

The compliance of the above mentioned products with the specified requirements of the applicable directives and harmonized and
non-harmonized standards is shown in the following internal and external test reports:

"W5A EMC Report.pdf ", "W5A Safety Report.pdf " and "W5A_Test_Reports.pdf"

CE Label attached to the product(s):

on minirack, on tabletop, on 19" subrack (for LTU only)

Issued by:

Schmid Telecom AG

Binzstrasse 35

CH-8045 Zurich

Place and date:

Zurich, 15.10.2001

Signatures:

Signature 1



Ronny Colotto

Signature 2



Walter Büchel

Contents

1	The Watson 5 Family	1
1.1	Important Safeguards	2
1.2	Ordering Information.....	4
1.2.1	LTU	4
1.2.2	NTU	4
1.2.3	Accessories.....	5
2	Installation Guide	7
2.1	Preparations	7
2.2	Installation Requirements	7
2.3	Installing a Watson Modem	8
3	Interface Configuration Options	9
3.1	DSL.....	9
3.1.1	Master / Slave	9
3.1.2	Line Rate	10
3.1.3	Power Back-off	11
3.1.4	Symmetric and Asymmetric PSD Mask	11
3.2	E1 Interface (2 Mbit/s G.703 / G.704).....	11
3.2.1	Framing.....	11
3.2.2	AIS Generation	12
3.2.3	AIS Detection.....	12
3.2.4	E1 Clock Modes	12
3.3	ISDN PRA Interface.....	14
3.3.1	PRA Mode	15
3.3.2	CRC4 Processing Options	15
3.3.3	Generation of CRC4 Error Notifications to the ET	19
3.4	nx64 kbit/s Interface.....	20
3.4.1	Features	20
3.4.2	User Interface Type.....	20
3.4.3	Bit Rate	20
3.4.4	V.54 Loops and Loop Control	20
3.4.5	Handshake Operation	21
3.4.6	Supported V.54 Loops	21
3.4.7	Automatic Loop Control through the DTE/DCE Interface	21

3.4.8	Clock Polarity	22
3.4.9	Byte Timing.....	22
3.4.10	Multiservice / nx64 Clock Modes	22
3.4.11	Clock Direction.....	23
3.5	Time Slot Mapping	23
3.5.1	E1 to frE1 Time Slot Mapping.....	23
3.5.2	nx64 kbit/s to nx64 kbit/s Time Slot Mapping.....	24
3.5.3	E1 to nx64 kbit/s/Ethernet Time Slot Mapping	24
3.5.4	E1 to E1 & nx64 kbit/s Multiservice Time Slot Mapping	25
3.5.5	Time Slot Mapping Overview	25
3.6	TMN Interface (Minirack LTU only).....	26
3.6.1	TIA/EIA-485 4-wire Bus	26
3.6.2	TIA/EIA-485 2-wire Bus	27
3.6.3	TIA/EIA-485 Bus Termination	28
4	Performance Monitoring.....	31
4.1	Noise Margin SNR.....	31
4.2	G.826 Performance Monitoring	31
4.2.1	DSL Interface.....	31
4.2.2	E1 Interface.....	32
4.2.3	ISDN PRA Interface	33
5	Alarms.....	35
5.1	LEDs	35
5.1.1	Status LEDs.....	35
5.1.2	Alarm Conditions	36
5.2	Alarm Relays	37
5.2.1	LTU	37
5.2.2	NTU	38
5.3	Alarm Display in Monitor Menus.....	38
6	Power Concept	39
6.1	LTU	39
6.1.1	Power and Grounding	39
6.2	NTU	39
6.2.1	Power and Grounding	39
6.2.2	Power Failure Alarm.....	40
6.3	Remote Powering	40
7	Monitor	42
7.1	General.....	42
7.2	Addressing	42
7.2.1	LTU	42
7.2.2	LTU Minirack	44
7.2.3	NTU	44
7.3	Structure and Organization	45
7.3.1	Available Shortcuts for Commands.....	46
7.3.2	Performance Management PM	46

7.3.3	Fault and Maintenance Management FMM.....	50
7.3.4	Configuration Management CM	58
7.3.5	Accounting Management AM	68
7.3.6	Security and Remote Management SM	68
7.4	Monitor Commands for the nx64 kbit/s Interface	69
7.4.1	Fault and Maintenance Management FMM.....	69
7.4.2	Configuration Management CM	70
7.5	Monitor Commands for LTU Minirack TMN Interface.....	75
7.5.1	ADDRESS Command	76
7.5.2	V.11 WIRES Command.....	77
8	Point-to-Multipoint Operation	79
8.1	Features	79
8.2	Configuration	80
8.2.1	E1 and DSL Interface Configuration	80
8.2.2	Assignment of E1 Time Slots to the DSL Loops	81
8.2.3	DSL Time Slot Selection.....	81
8.2.4	MP Command	83
8.2.5	Cascading Multipoint LTUs	84
8.3	LEDs	87
8.3.1	Status LEDs.....	87
9	Front and Rear Panel Description	89
9.1	Tabletop NTU, Rear Panel	89
9.2	Plug-in LTU, Front Panel.....	90
10	Connectors' Description	91
10.1	DSL Connector	91
10.2	E1 Connector	92
10.2.1	Impedance 120 Ω	92
10.2.2	Impedance 75 Ω	93
10.3	nx64 kbit/s Connector.....	94
10.3.1	User Interface Type.....	94
10.3.2	nx64 kbit/s Cables	96
10.4	Monitor Connector (NTU)	102
10.5	48V _{dc} Power Connector (NTU)	103
11	Technical Specifications.....	105
11.1	Interfaces.....	105
11.1.1	DSL Line Interface	105
11.1.2	User Interface	105
11.1.3	Monitor Interface	106
11.2	Power Supply.....	107
11.2.1	LTU	107
11.2.2	NTU	107
11.3	Environment	107
11.3.1	Climatic Conditions	107
11.3.2	Safety	107

11.3.3	EMC.....	108
11.4	Physical Dimensions.....	108
11.4.1	LTU	108
11.4.2	NTU	108
12	Firmware Download	109
12.1	Download Procedure	109
12.2	Download transport via ACU.....	110
12.3	Download transport via CMU	111
12.4	Download transport via Modem Chain.....	112
12.5	Remote Firmware Download Procedure.....	112
13	Diagnostics and Troubleshooting.....	114
13.1	Test Loops.....	114
13.2	Hints for Troubleshooting.....	115
13.2.1	Problems	115
13.2.2	Initialization Errors	116
14	Appendix.....	117
14.1	Abbreviations	117
14.2	Referenced Documents.....	119

Figures

Figure 3-1:	Clock Sources.....	13
Figure 3-2:	Synchronous Operation (=“Loop Timing”)	13
Figure 3-3:	External Clock Mode	14
Figure 3-4:	Reference Points of the PRA	15
Figure 3-5:	Digital Link without CRC Processing	16
Figure 3-6:	Digital Link with CRC Processing in the NT1.....	17
Figure 3-7:	Digital Link with CRC Processing in the LT and NT1	18
Figure 3-8:	Digital Link with CRC Monitoring in the NT1	19
Figure 3-9:	Time Slot Mapping: 16 frE1 Time Slots to E1.....	24
Figure 3-10:	Time Slot Mapping: 16 nx64 Time Slots to nx64	24
Figure 3-11:	Time Slot mapping: 16 nx64 Time Slots to E1.....	24
Figure 3-12:	Time Slot mapping: 16 nx64 Time Slots and 16 frE1 Time Slots to E1	25
Figure 3-13:	TMN Bus 4-Wire Connection for Minirack Units.....	27
Figure 3-14:	TMN Bus 2-Wire Connection for Minirack Units.....	27
Figure 3-15:	TMN Bus 2-Wire Connection for Plug-in Units	28
Figure 3-16:	Termination for Long TMN Bus	29
Figure 4-1:	E1 G.826 Performance Evaluation.....	32
Figure 4-2:	PRA G.826 Performance Evaluation.....	33
Figure 6-1:	Line feed current vs loop resistance for different NTU power consumptions.....	41
Figure 7-1:	LTU Interface Addressing Scheme.....	43
Figure 8-1:	Examples of Multipoint Configuration.....	79
Figure 8-2:	Cascading of Multipoint LTUs.....	85

Figure 10-1: DSL Connector Backview	91
Figure 10-2: Front-view nx64 Sub-D25 connector	94
Figure 13-1: Standard Test Loops	114

Tables

Table 1-1: Ordering Numbers for Watson 5 LTU	4
Table 1-2: Ordering Numbers for Watson 5 NTU	4
Table 1-3: Ordering Numbers for Watson 5 Accessories	5
Table 3-1: TS distribution over 1p, 2p and 4p operation	10
Table 3-2: Time slot mapping overview	26
Table 5-1: LED indication	35
Table 5-2: Alarm LED function	35
Table 5-3: LED indication during firmware download	36
Table 7-1: Command Shortcuts	46
Table 7-2: 3p and 4p limitations	65
Table 8-1: LED Indication	87
Table 10-1: DSL connector pin assignment	91
Table 10-2: Pin Assignment E1 120 Ohm connector	92
Table 10-3: Pin Assignment 1200hm E1 Sub-D9 connector	93
Table 10-4: Pin assignment nx64 Sub-D25 connector	94
Table 10-5: Signal Description of nx64 connector	95

1 The Watson 5 Family

The Watson 5 family is a SHDSL/SDSL transmission system compliant to:

- ITU-T G.991.2 Annex B (G.shdsl) and
- ETSI TS 101 524 (ETSI SDSL).

It is based on a Trellis-coded PAM16 linecode supporting multiple line rates as well as 1 pair, 2 pair, and 4p DSL transmission. It was designed with flexibility and modularity in mind. It supports both full and fractional E1 data rates, in either framed or transparent mode, Primary-Rate-Access (PRA) as well as nx64 kbit/s interfaces (V.35, V.36, X.21).

Watson 5 Multiservice offers flexible transmission with data from both frE1 and nx64kbits/s. The time slots assignments of E1 as well as of nx64kbit/s interface are configurable.

Watson 5 Multipoint LTUs present a versatile platform for point-to-multipoint operations of multiple NTUs:

- A single Multipoint LTU with two E1 interfaces can be connected with up to 4 NTUs in various configurations.
- For applications where the data volume of single links is not a primary concern, LTUs can be cascaded to enlarge the number of serviceable links.
- Maximal data transfer is gained with dual link operation of the multipoint LTU at full E1 rate.

Multipoint features can be flexibly configured such as mapping of the time slots to user interfaces, line rates of each pair of links, data rates of each link (i.e. time slots).

The Line-Termination-Units (LTU) are available as 19" subrack card or as minirack version. The LTU may be configured (via jumper) as LTU-L or LTU-R. The LTU-R is capable of remotely powering remote NTUs. The LTU-R is only master configurable, whereas the LTU-L is both master and slave configurable.

The Network-Termination-Unit (NTU) is available as a tabletop unit or as a minirack version. A slide switch as either NTU-R or NTU-L may configure the NTU. An NTU-R is remotely powered by an LTU-R, whereas an NTU-L is powered by a 230V/48V mains adapter.

An Alarm Control Unit (ACU) in the subrack enables the connection of the EIA485-bus, the EIA232 Monitor interface, and the alarm relays.

An optional Control and Management Unit (CMU) in the 19" subrack acts as an SNMP agent and brings TMN facilities to the system.

1.1 Important Safeguards

This section describes the safety precautions the user should abide by when operating this equipment.

- Transport this equipment in its original packaging or by using appropriate materials to prevent against shock and impact.
- Before setting up this product for operation please make note of the accompanying environmental requirements.
- Slots and openings in the unit are provided for ventilation. To ensure reliable operation and to protect it from overheating these slots and openings must not be blocked or covered.
- Condensation may occur externally or internally if this equipment is moved from a colder room to a warmer room. When moving this equipment under such conditions, allow ample time for the equipment to reach room temperature and to dry before operating.
- Note that normal operation (in accordance with EN 60950) is only possible when the external housing is left in place (ventilation, fire prevention, and radio interference).
- Before supplying power, verify the power rating identified on the marking label complies with the local power source.
- Do not allow anything to rest on any of the attached cables and do not locate the product where persons will walk or trip on the cables.
- Connect this equipment only to an approved, properly grounded, and accessible socket outlet. To completely turn off this equipment you must remove the power cord from the system.
- Avoid connecting or disconnecting data lines during lightning storms.
- Follow the accompanying instructions when connecting the required cabling.
- Make sure no foreign objects or liquids come into contact with the internal components (danger of shock or short circuit).
- In an emergency (e.g., damaged external housing or internal elements, liquid spills) immediately remove the power cord and notify customer service.
- Electrostatic electricity can damage internal components. Ground yourself before touching any internal components.
- Never use water to clean this device. If water reaches the internal parts, extreme danger may result to the user or the equipment.
- Never use scouring or abrasive cleaning agents, or agents containing alkaline on device. Damage of the device's exterior may result.

Information for the Technician

- Remove the network and power supply cables before opening this equipment or removing the plug-in units, respectively.

Safety Notices

Do not proceed any of these notices until you have fully understood the implications:

- Caution! Potential hazard that can damage the product.
- Important! Potential hazard that can seriously impair operation.

1.2 Ordering Information

1.2.1 LTU

<i>Description</i>	<i>Product Number</i>
	<i>Plug-in</i>
W5 LTU E1/1200hm & nx64, single link 1p	SZ.866.V318Wxx
W5 LTU E1/750hm & nx64, single link 1p	SZ.866.V338Wxx
W5 LTU E1/1200hm & nx64, single link 2p	SZ.866.V418Wxx
W5 LTU E1/750hm & nx64, single link 2p	SZ.866.V438Wxx
W5 LTU 2*E1/1200hm, dual link 1p	SZ.866.V511Wxx
W5 LTU 2*E1/750hm, dual link 1p	SZ.866.V533Wxx
W5 LTU 2*nx64, dual link 1p	SZ.866.V588Wxx
W5 LTU 2*E1/1200hm, dual link 2p	SZ.866.V711Wxx
W5 LTU 2*E1/750hm, dual link 2p	SZ.866.V733Wxx
W5 LTU 2*nx64, dual link 2p	SZ.866.V788Wxx

Table 1-1: Ordering Numbers for Watson 5 LTU

1.2.2 NTU

<i>Description</i>	<i>Product Number</i>
	<i>Tabletop</i>
W5 NTU E1/PRA/1200hm, single link 1p	SZ.886.V310Wxx
W5 NTU E1/1200hm & nx64, single link 1p	SZ.886.V318Wxx
W5 NTU E1/PRA/750hm, single link 1p	SZ.886.V330Wxx
W5 NTU E1/750hm & nx64, single link 1p	SZ.886.V338Wxx
W5 NTU nx64, single link 1p	SZ.886.V380Wxx
W5 NTU E1/PRA/1200hm, single link 2p	SZ.886.V410Wxx
W5 NTU E1/PRA/1200hm & nx64, single link 2p	SZ.886.V418Wxx
W5 NTU E1/PRA/750hm, single link 2p	SZ.886.V430Wxx
W5 NTU E1/PRA/750hm & nx64, single link 2p	SZ.886.V438Wxx
W5 NTU nx64, single link 2p	SZ.886.V480Wxx
W5 NTU E1/PRA/120 Ohm, single link 4p	SZ.886.V810Wxx
W5 NTU E1/PRA/75 Ohm, single link 4p	SZ.886.V830Wxx
W5 NTU nx64, single link 4p	SZ.886.v880Wxx

Table 1-2: Ordering Numbers for Watson 5 NTU

- Notes:**
- x = W, as a default for the general version
 - x = other letter than W standing for customer-specific version

1.2.3 Accessories

Subrack	SZ.379.V3W
ACU2R	SZ.369.V5W
ACU48R	SZ.369.V4F
Nx64kbit/s Cables	
V.35 DTE, 3m length	SZ.378.0F1.V1
V.35 DCE, 3m length	SZ.378.0G1.V1
V.36 DTE, 3m length	SZ.378.0H1.V1
V.36 DCE, 3m length	SZ.378.0J1.V1
X.21 DTE, 3m length	SZ.378.0K1.V1
X.21 DCE, 3m length	SZ.378.0L1.V1
AC/DC Adapter, 230V version	SZ.378.0A0.V1
AC/DC Adapter 230V, 15W	SZ.378.0A0.V2
AC/DC Adapter, 115V version	SZ.378.0A0.V3
DC/DC Adapter, 48/60V	SZ.378.0A0.V5
19" Minirack Mechanics LTU	SZ.876.V100W
19" Minirack Mechanics NTU	SZ.896.V100W

Table 1-3: Ordering Numbers for Watson 5 Accessories

2 Installation Guide

This chapter gives a brief overview over the necessary steps to install a Watson modem.

2.1 Preparations

Before going to the installation site, check what you need of the following equipment in addition to the modem:

- AC/DC Power adapter or supply cable (for tabletop or minirack NTU)
- DSL cable
- Network cable
- Monitor cable and terminal
- Mounting material

In case your installation requires special DSL cabling or rack mounting, check what you need of the following tools:

- Wire stripping tool appropriate for the cable size.
- Crimp tools for connectors
- Screwdrivers

2.2 Installation Requirements

Installation of this equipment has to be done by qualified personnel only.

To achieve safety and satisfactory EMC performance, the plug-in LTU has to be inserted into the subrack. Subrack slots that are not used have to be covered with blanking plates.

The subrack or minirack must be bonded to earth. This is usually achieved by installing the subrack or minirack into a rack which is connected to the earthing network according to ETS 300 253.

Additionally, on the subrack an extra earth terminal for connection to the FPE connector (Functional Protective Earth) is provided.

2.3 Installing a Watson Modem

- Unpack and mount the unit safely. Keep chapter "Important Safeguards" in mind when choosing an appropriate place for tabletops. Miniracks can be mounted in 19" racks.
- Plug-in units are simply inserted into subracks and will start operation immediately. Mounting of subracks is described in manual "Installation Manual of Subrack".
- Check the setting of the remote power switch/jumper.
 - NTU In the default switch position "Rem", the NTU modem is powered via the xDSL line and will start operation immediately after connection of the xDSL line. In case the remote LTU modem does not support power feeding, local power supply is needed for operation. In position "Loc", the NTU modem is powered locally and needs the power supply connected to operate.
 - LTU In the default jumper positions "RPWR A ON", "RPWR B ON", .. the LTU modem is powering the remote NTU unit. In jumper position "OFF", the remote powering function is disabled.

Caution: LTUs must be disconnected from power during change of jumper setting. See chapter "Power concept"; section "Remote powering" for further information.

- Connect the modem to the network or PC. Plug the appropriate cable to the interface connector on the unit. Refer to chapter "Connectors' Description" for cable definitions.
- Connect the modem to the DSL line. If using a preconfigured cable, just connect the xDSL line with male RJ45 cable into the female RJ45 connector of the modem. If you need to configure the cable, refer to chapter 10 "Connector Description"; section "DSL Connector".
- NTUs in remote power mode will start operation immediately with factory default settings, and further configuration is optional.
- Optional: Connect the power supply. For local power supply of NTUs, connect the AD/DC power adapter (ordered separately) to the mains and to the unit. The power adapter is optional for NTUs in remote power mode. Minirack LTUs can be connected directly to mains, to a 48V_{DC} source or both at the same time. Plug-in units are powered via the subrack backplane. See chapter "Power concept" for further information.
- Optional: Configure the unit. Connect a VT100 terminal using the serial monitor cable to the "Monitor" connector of the unit or of the subrack.

Important: Check DSL mode configuration "master/slave". There must be a "master" unit connected to a "slave" unit for proper operation. The configuration of a "slave" unit can also be done via the "master" unit. Refer to chapter "Monitor Operation" for detailed information.

- Check the proper operation. The LED "Local" lights green in normal operation. In "slave" mode, the LED "Remote" is off, but should light green for normal operation in "master" mode. See chapter "Alarm Indication" for further information.

Watson modems are generally very easy to install; usually just plugged to the DSL line and to the network. If more configuration is needed, the operator is supported by comprehensive menus, default settings, plausibility checks and helpful warning messages. This way, the operator can easily control the wealth of powerful functions that Watson modems provide.

3 Interface Configuration Options

The following sections describe the various configuration options. On the plug-in LTU, the operating modes are configurable via the V.24 monitor interface or via the TMN interface of the ACU, whereas on the minirack LTU, table-top NTU and minirack NTU, they are directly configurable via the monitor interface. If the LTU/NTU is slave, it is also configurable from the master side. Only the remote/local powering has to be configured via jumpers on the board of the LTU or via slide switches on the NTU.

3.1 DSL

The following configuration options refer to the DSL side and do not affect the user interface operating mode.

3.1.1 Master / Slave

To start up a DSL link, one system unit must be configured as master and the other one as slave. The master controls the link start-up procedure. *If both system units are configured as master or as slave, no start-up will occur.*

Usually, the LTU is configured as master and the NTU as slave (default setting). However, it is possible to set up a DSL link with two LTUs or two NTUs, as long as one is configured as master and the other one as slave. In these cases, remote powering is not possible. To configure a LTU as a slave it is necessary to set the R/L jumpers located on the PCB in position "RPWR OFF". Generally, the master-slave permissions are:

- The slave unit has only the permission to change its own configuration locally. It cannot access nor modify the master unit's configuration or data. Access to the slave unit's configuration or data is possible via local monitor or via the master unit.
- The master unit has local access as well as remote access to the slave unit. For safety reasons, only the master / slave configuration and the autorestart option cannot be altered by the master unit over the DSL link.

When the "Remote" LED on the front panel of the NTU is lit, the system unit is configured as master.

3.1.2 Line Rate

According to ETSI TS 101 524 Watson 5 supports payload bit rates on multiples of 64 kbit/s with the optional use of Z-bits.

$$\text{Payload Block Bit Rate} = N * 64 \text{ kbit/s} + i * 8 \text{ kbit/s}$$

with $3 \leq N \leq 36$ and $i = 0, 1$

Watson 5 offers the option of configuring one Z-bit as a supplementary bandwidth enhancement to the embedded operating channel (EOC) within the SHDSL overhead.

The effective bandwidth of the eoc without Z-bits is 3.2 kbit/s within the total of 8 kbit/s SHDSL overhead.

Watson 5 offers the option of configuring 2p and 4p operation of the data transmission if this feature is supported by the corresponding modems.

The corresponding line rates for each pair are:

$$\text{Line Rate} = \frac{N * 64 \text{ kbit/s}}{\text{Number of Pairs}} + \underbrace{8 \text{ kbit/s}}_{\substack{\text{SHDSL OH} \\ \text{incl. EOC}}} + \underbrace{8 \text{ kbit/s}}_{\substack{\text{optional} \\ \text{Z-bits}}}$$

Therefore in order to set up the basic transmission parameters one has to configure the line rate, the number of transmission pairs, and the use of optional Z-bits for increasing the capacity of the embedded operating channel.

Note: In spite of the fact that a lot of different line rates or payload bit rates can be configured performance (noise margin of testloops) is evaluated only for a small subset of payload bit rates according to ETSI TS 101 524:

		<i>1p transmission</i>	<i>2p transmission</i>	<i>4p transmission</i>
N	Payload bit rate used in test loops (kbit/s)	DSL time slots TS per pair		
6	384	6	-	-
8	512	8	-	-
12	768	12	6	-
16	1024	16	8	-
20	1280	20	-	-
24	1536	24	12	6
32	2048	32	16	8
36	2304	36	-	-

Table 3-1: TS distribution over 1p, 2p and 4p operation

3.1.3 Power Back-off

In order to reduce ingress on other transmission systems operating on adjacent pairs bundled in the same cable, the transmit power of LTU and NTU can be decreased by activating the power back-off mode.

3.1.4 Symmetric and Asymmetric PSD Mask

For payload bit rates of 2048 kbit/s and 2304 kbit/s the Power Spectral Density (PSD) masks of LTU and NTU can be switched into symmetric or asymmetric mode. Activating asymmetrical PSD masks will increase transmit power of LTU and NTU and by this the possible loop length. The PSD masks of LTU and NTU will have different (asymmetric) shapes in this operation mode.

3.2 E1 Interface (2 Mbit/s G.703 / G.704)

3.2.1 Framing

3.2.1.1 Transparent Mode

In transparent mode, the E1 data will be transmitted without any changes, whereas in framed mode, the frame / multiframe alignment words and CRC4 bits are regenerated by the E1 framer. The "CRC4 " and "E-bit Insertion" options are not relevant in transparent mode.

3.2.1.2 Framed Mode ITU-T G.704

In framed mode (framing according to ITU-T G.704), the incoming E1 data stream passes through an E1 framer before entering the DSL section. From the other side, the same process happens in reverse; the E1 data stream received from the DSL section first passes through the E1 framer before being transmitted to the E1 network.

The E1 framer operates in Common Channel Signaling (CCS) mode. Time slot 16 and all national bits are fully transparent.

Consider the "CRC4" and "E-bit Insertion" options when operating in framed mode.

3.2.1.2.1 CRC4

If operating in framed mode, the "CRC4" option can be used to adapt to specific E1 network requirements:

- If enabled, the E1 framer will synchronize on CRC4 multiframes and CRC4 errors will be reported. In the outgoing E1 signal the framer regenerates the CRC4 multiframe alignment and checksum words. The A-Bit and the Sa-Bits pass transparently.
- If disabled, the international bits are set to '1' in the outgoing E1 signal. All national bits are fully transparent. On the receive side, the E1 framer will synchronize on basic frames only and no CRC4 errors will be reported.

3.2.1.2.2 *E-bit Insertion*

- If automatic E-Bit generation is enabled, detected CRC4 errors will cause the assertion of the E-bits.
- If disabled, all E-Bits are set to '1'.

3.2.2 *AIS Generation*

If this option is enabled, an unframed AIS (all ones) will be transmitted on the E1 side, irrespective of whether the system is configured in transparent or framed mode.

AIS generation will be activated on the following conditions:

- DSL link to the remote station is not established (loss of signal or loss of frame alignment on DSL side) or
- remote station is sending AIS-R.

If AIS generation is disabled, no signal will be transmitted on the E1 side if either of these two conditions occurs.

3.2.3 *AIS Detection*

If AIS detection is enabled, receiving AIS from the E1 side will cause the following actions:

- The Non-Urgent alarm will be set active (AIS-S).
- AIS will be transmitted to the remote station by AIS-R.

3.2.4 *E1 Clock Modes*

3.2.4.1 *Clock Sources*

The following block diagram shows the possible clock sources for the LTU and the NTU (Note, that the external clock option is not available for the NTU!). The clock sources are intended to be references only and do not drive the DSL transmit section physically.

Data rate adaptation between the 2048kHz clock and the DSL transmit clock is achieved by stuffing / deleting bits in the DSL frames.

The crystal controlled DSL clock never affects the E1 interface clock.

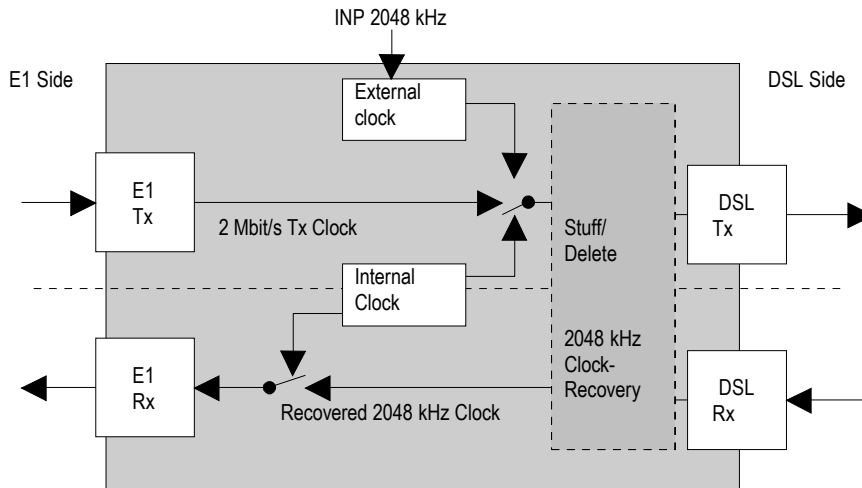

Figure 3-1: Clock Sources

Note: Signals towards the transceiver section are denoted as Tx and signals coming from the transceiver sections are denoted as Rx.

As long as the DSL link is not established, the internal clock oscillator is used as clock source. The clock sources are automatically switched by the microcontroller, depending on the actual signal and clock status, which is updated every 100 ms.

The transmit clocks of the two E1 data directions are independent of each other. Both plesiochronous and synchronous operation modes are possible. Synchronous operation occurs when the E1 equipment at one end of the DSL link uses the receive clock as transmit clock, as shown below.

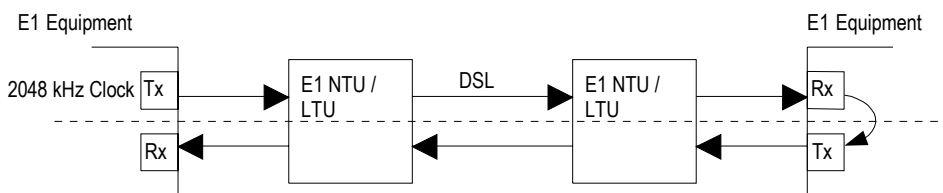

Figure 3-2: Synchronous Operation (= "Loop Timing")

Warning: Do not configure the E1 interfaces at both ends to use the receive clock as transmit clock except if one DSL equipment is an LTU using the "External Clock" option. Otherwise there will be no defined clock.

3.2.4.2 External Clock Mode

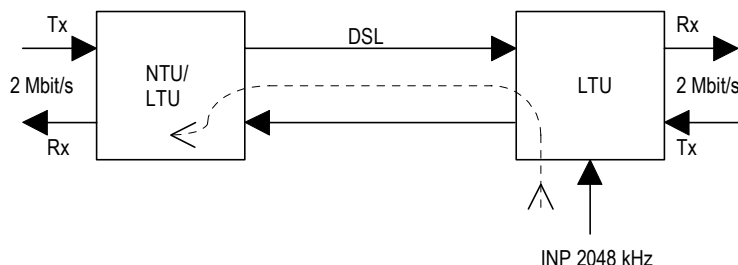

Figure 3-3: External Clock Mode

In “External Clock” mode, the 2048kHz input clock is fed directly in the LTU in case of the minirack or via the ACU clock input in case of the plug-in LTU. The external clock is used as the E1 reference clock.

If the “External Clock” option is enabled, the primary E1 clock source is the external clock. If no external clock is present at the 2048kHz clock input, the E1 transmit clock is used as the clock source. If no signal is received at the E1 Port, then the internal clock is used as the clock source.

If the “External Clock” option is disabled, the primary E1 clock source is the 2Mbit/s transmit clock. If no signal is received at the E1 Port, then the internal clock is used as the clock source.

The external clock is never used to drive the E1 Rx direction.

Note: There is neither an external clock input nor a clock output on the NTU side. The E1 Tx clock rate is defined by the incoming E1 Tx data rate. The Rx clock rate is the recovered Tx clock rate of the remote side or the local internal clock. The primary E1 Rx clock source is the recovered 2048kHz clock.

3.3 ISDN PRA Interface

In PRA mode, the DSL modem offers the functions of an ISDN PRA NT1, a LT or a combination of the functions of NT1 and LT. This makes it possible to use two set-ups:

- The slave modem at the customer premises is configured as NT1; the master modem at the central office is configured as LT.
- The slave modem at the customer premises is configured as NT1 & LT. Direct access to the exchange is established by a bit-transparent DSL-Link. All data, including time slot 0, from the exchange must be transmitted transparently (also time slot 0) to the PRA-NTU, therefore the DSL equipment providing the line termination is E1 working in transparent mode (see Figure 3-4).

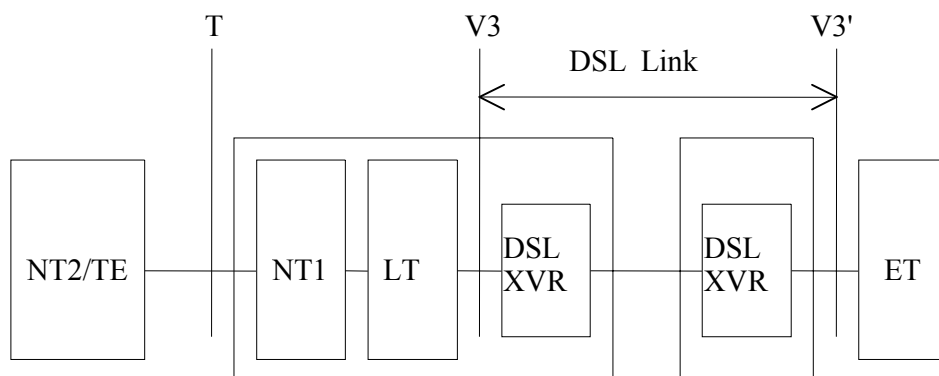

Figure 3-4: Reference Points of the PRA

Normally, the PRA-digital section (NT1 and LT) is configured as a digital link with CRC processing in the NT1 (option 2, according to I.604). However, also the other subscriber access options described in I.604 Annex A, can be configured. One of the DSL system units must be configured as master and the other as slave. Normally, the LTU (or the NTU, respectively) at the exchange is configured as the master on the DSL link, and the PRA-NTU as slave.

The equipment described above provides an access digital section for ISDN primary rate at 2048kbit/s. The 120 Ω port (or optionally the 75 Ω In/Out BNC) is the user/network-interface for primary rate access, which is denoted as T reference point in ISDN terminology. The equipment at the user side of the T reference point, which may be TE1, TA or NT2, is termed TE or NT2 in the normative references. Therefore, it is denoted as NT2/TE in this document. The interface towards the exchange, which will be abbreviated ET in the following, is the V3 reference point.

3.3.1 PRA Mode

The modem can work as NT1, LT or NT1 and LT combined.

3.3.2 CRC4 Processing Options

In addition to the usual PRA operation with CRC4 processing in both directions, the PRA interface also offers other modes of operation. Following ITU-T Rec. I.604 Annex A, three subscriber access options for a digital link are supported. The PRA interface can be configured to work either as a digital link without CRC processing (option 1), a digital link with CRC processing in the NT1 (option 2) or a digital link with CRC monitoring only in the NT1 (option 4). A digital link with CRC processing in the LT and NT1 is possible by using a DSL link consisting of an NT1 and an LT, both configured with CRC processing on.

3.3.2.1 Digital Link without CRC Processing (Option 1)

In this mode, transparent transmission between the ET and the NT2/TE is possible. There is no CRC4 processing in the PRA-NTU; the CRC processing is only done in the ET and the NT2/TE.

When loss of incoming signal is detected on either side, AIS is transmitted at the opposite side.

The detection of events and the state information are still valid as in normal PRA operation mode (option 2).

Depending on the distribution of NT1 and LT functionality, two set-ups are possible for option 1:

- The master is E1 configured transparent, AIS-generation on and AIS-detection off; the slave is PRA NT1 & LT, CRC4 processing off.
- The master is PRA LT with CRC4 processing off; the slave is PRA NT1 with CRC4 processing off.

Note: For proper operation in Option 1, the equipment at the customer side (NT2) and at the central office side (ET) must be in CRC4 framed mode.

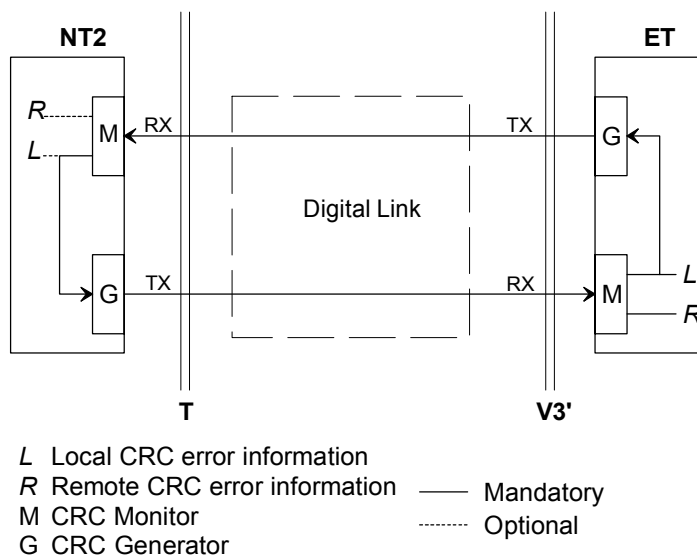

Figure 3-5: Digital Link without CRC Processing

3.3.2.2 Digital Link with CRC Processing in the NT1 (Option 2)

This is the usual PRA operating mode as described in ETS 300 233 and ITU-T Rec. G.962 Annex B. The PRA interface is intended to be used in this mode.

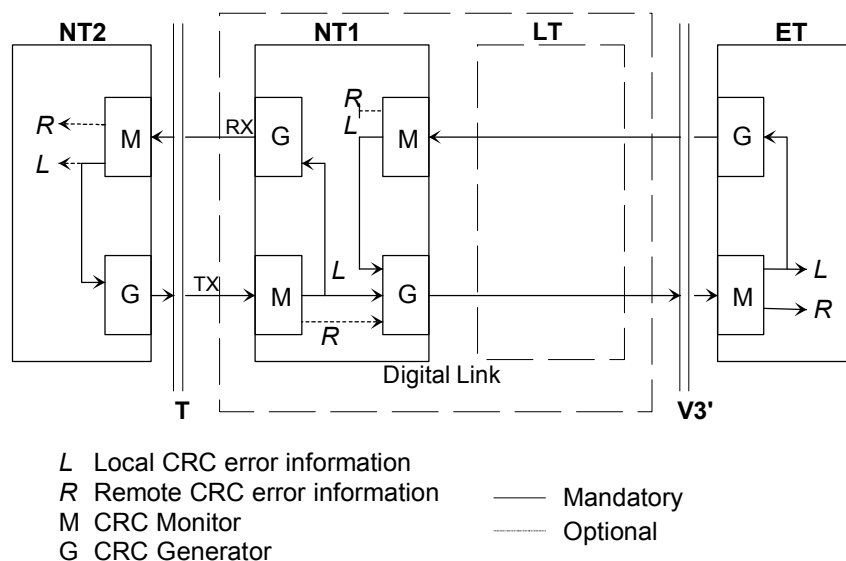

Figure 3-6: Digital Link with CRC Processing in the NT1

CRC4 is generated towards the NT2/TE and towards the ET and monitored at both sides of the NT1. When a block with a CRC4 error is received from the NT2/TE, CRC4 error information is transmitted towards the NT2/TE (via E-bits) and optionally towards the ET (via Sa6-bits). When a block with a CRC4 error is received from the ET, error information is transmitted towards the ET (via E-bits). CRC4 errors detected at the T reference point of the NT2/TE are reported to the NT1 (via E-bits) and optionally towards the ET (via Sa6-bits). CRC4 errors detected at the V3 reference point of the ET are reported to the NT1 (via E-bits). Loopback 1 and 2 control facilities and monitoring of defect conditions are implemented according to ETS 300 233.

Depending on the distribution of NT1 and LT functionality, two set-ups are possible for option 2:

- The master is E1 configured transparent, AIS-generation on and AIS-detection off; the slave is PRA NT1 & LT, CRC4 processing on.
- The master is PRA LT with CRC4 monitoring on; the slave is PRA NT1 with CRC4 processing on.

3.3.2.3 Digital Link with CRC Processing in the LT and NT1 (Option 3)

In this mode, the NT1 behaves like in option 2. The LT is not transparent, but has CRC4 generation and monitoring in both directions. This option is not possible when using combined NT1 & LT mode, the set-up for option 3 is:

- The master is PRA LT with CRC4 processing on; the slave is PRA NT1 with CRC4 processing on.

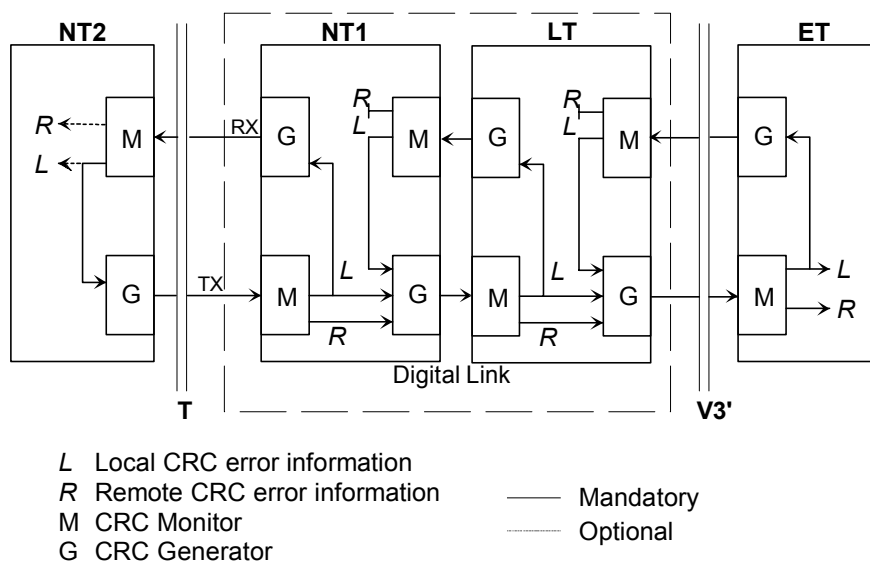

Figure 3-7: Digital Link with CRC Processing in the LT and NT1

3.3.2.4 Digital Link with CRC Monitoring in the NT1 (Option 4)

CRC4 multiframe alignment and checksum words are not regenerated in both directions, i.e. data will be transmitted without changes in both directions. However, blocks with CRC4 errors received from the NT2/TE and the ET will be detected and monitored by the G.826 performance management functions of the NTU monitor.

When loss of signal or loss of frame alignment is detected at either side, AIS is transmitted at the opposite side.

The detection of events and the state information are still valid as in normal PRA operation mode (option 4).

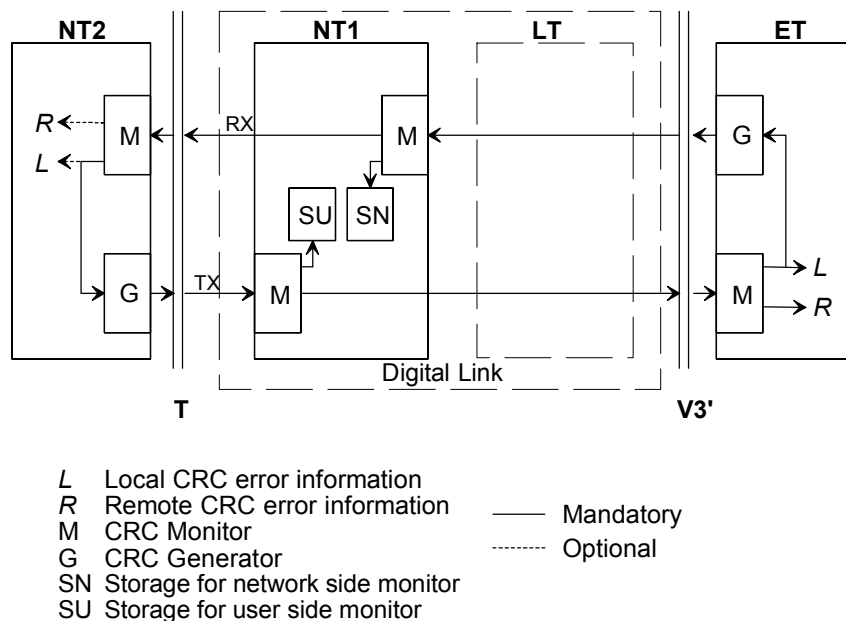

Figure 3-8: Digital Link with CRC Monitoring in the NT1

Depending on the distribution of NT1 and LT functionality, two set-ups are possible for option 1:

- The master is E1 configured transparent, AIS-generation on and AIS-detection off; the slave is PRA NT1 & LT, CRC4 monitoring on.
- The master is PRA LT with CRC4 processing off; the slave is PRA NT1 with CRC4 monitoring on.

3.3.3 Generation of CRC4 Error Notifications to the ET

For enhanced maintenance capabilities, CRC4 errors detected at the interface at the T reference point may optionally be reported to the ET (see ETS 300 233 section 8.3 and table 4 of ITU-T Rec. G.962 section B.5 and table B.2). CRC blocks in error detected at the T reference point of the NT1 as well as CRC error indications received from the NT2/TE in the E-bits are reported to the ET by using the Sa6-bits. An ET applying asynchronous detection of the Sa6-bits (no synchronization of the Sa6-bits to the sub-multiframe) will misinterpret such CRC4 error reports from the NT1 with other defect indications, e.g. loss of power at NT1 or FC4. Therefore, this Sa6-bits indication can be disabled.

- If the CRC4 error notification in Sa6 is enabled, Sa6=0001 indicates an E-bit received from the NT2/TE, Sa6=0010 indicates a CRC4 error detected at the T reference point of the NT1, and Sa6=0011 indicates the simultaneous occurrence of both errors.
- If disabled, Sa6 is always 0000 in normal operation state.

As sending of Sa-bits requires regeneration of the CRC4 frames in the NT1, this option is only activated when option 2 (Digital link with CRC processing in the NT1) is selected.

3.4 nx64 kbit/s Interface

This chapter describes the configuration options and alarms related to the nx64 kbit/s user interface.

3.4.1 Features

- The nx64 kbit/s interface is software-configurable between V.35, V.36 and X.21.
- The bit rate can be selected in steps of 64kbit/s from 64kbit/s (n=1) up to 2304kbit/s (n=36, Dual LTU) and 4608 kbit/s (n=72, NTU).
- Independent receiving and transmitting clocks for V.35 and V.36.
- Co-directional (from equipment connected to nx64 Port) and contra-directional (clock generated by internal reference or from receiving clock recovery) transmitting clocks are possible.
- Detection for loss of clock and clock rate mismatch in co-directional clock mode.
- Standard SubD25 connector (ISO 2110 for V.35, RS-530 for V.36, proprietary for X.21) for DCE operation, other connectors (ISO 2593 for V.35, ISO 4902 for V.36, ISO 4903 for X.21) both for operation as DCE or DTE are available by means of adapter cables.
- Loop 1 and Loop 2 supported, for V.35 and V.36 they can also be controlled by circuits 140 (RL) and 141 (LL), according to V.54.
- Support for byte timing (circuit B) in X.21 mode.
- Multiservice operation: With both an nx64 kbit/s and an E1 interface equipped, it is possible to use them concurrently and share the DSL bit rate between them.

3.4.2 User Interface Type

The interface mode can be set to V.35, V.36 or X.21.

3.4.3 Bit Rate

Dual LTU nx64 - NTU nx64 link:

- The bit rate can be selected in the range of 64 kbit/s up to 2304 kbit/s.

LTU E1&nx64 - NTU nx64 or NTU nx64 - NTU nx64 link

- The bit rate can be selected in the range of 64 kbit/s up to 4608 kbit/s in steps of 64kbit/s (n = 1..72).

3.4.4 V.54 Loops and Loop Control

As the X.21 interface provides only the control interchange circuits C and I, most of the features described afterwards are only applicable for V.35 and V.36, but not for X.21.

3.4.5 Handshake Operation

When no loopback is established, the control circuits perform this handshake protocol:

- 105 (RTS Request to send; X.21: C): Input from DTE. For X.21, C = OFF will cause a DTR alarm.
- 106 (CTS Ready for sending, X.21: I):
 - if Handshake option enabled: is set ON when a DSL connection is established and 105 = ON is detected.
 - if Handshake option disabled: is set ON when a DSL connection is established
- 107 (DSR Data set ready): is set ON when a DSL connection is established
- 108 (DTR Data terminal ready): input from DTE. For V.35 and V.36, 108 = OFF will cause a DTR alarm.
- 109 (RLSD Data channel received line signal detector): is set ON when a DSL connection is established.
- 140 (RL Loopback / Maintenance test): Input from DTE; will be set OFF in normal mode.
- 141 (LL Local loopback): input from DTE; will be set OFF in normal mode.
- 142 (TM Test indicator): is set OFF in normal mode.

3.4.6 Supported V.54 Loops

ITU-T recommendation V.54 defines four test loops. Loops 2 and 3 correspond to DSL loopbacks 2 and 1. The interchange circuits are set in the following way:

- V.54 Loop 3
Local loop established in the DCE, i.e. DSL loopback 1 in an nx64 kbit/s NTU/LTU. These output interchange circuits are set: 107 = ON and 142 = ON
- V.54 Loop 2
Loop in remote DCE, i.e. DSL loopback 2 in the remote (slave) NTU/LTU.
These output interchange circuits are set:
 - Master: 107 = ON and 142 = ON
 - Slave: 104 (received data) = 1, 106 = OFF, 107 = OFF, 109 = OFF and 142 = ON.

3.4.7 Automatic Loop Control through the DTE/DCE Interface

Automatic control through the interface is achieved by using circuits 140 and 141:

- 140 = ON and 141 = OFF \Rightarrow V.54 loop 2 (DSL loopback 2)
- 140 = OFF and 141 = ON \Rightarrow V.54 loop 3 (DSL loopback 1)

This automatic loop control can be switched on/off using the "V54LOOPS" configuration option.

The interface on the user side can be a DTE or a DCE. To connect them to the interface port, the V.35 DTE or V.35 DCE cable must be used.

3.4.8 Clock Polarity

In X.21 mode the sampling instant for the incoming data stream on circuit T of the user interface (UIF) can be switched to rising or falling slope of the contradirectional clock circuit S. Data transitions of the received data on UIF circuit R is not influenced by this setting.

In default configuration "normal" circuit T is sampled on rising edge of clock S. The data transitions on T and R shall occur at the OFF to ON transition of S (according X.24 standard). The ON to OFF transition of circuit S nominally indicates the centre of each signal element on circuit R in this case.

When Clock Polarity is set to "inverted", circuit T is sampled with the falling slope of S. The incoming data at X.21 circuit T will be sampled at the OFF to ON transition of S.

3.4.9 Byte Timing

In the X.21 mode, the byte timing circuit B according to X.24 can be activated (configuration option "BYTETIMING"). As the circuits B (byte timing) and X (co-directional transmit clock) share the same pins on the 15-pin ISO 4903 connector, separate cables have to be used for these cases.

3.4.10 Multiservice / nx64 Clock Modes

For V.35 and V.36, the receiving and the transmitting clock are independent. The receiving clock is always the recovered remote clock. The clock mode configuration applies only to the transmit clock. For X.21, there is only one clock (circuit S) to receive and transmit, the clock mode determines the source of that single clock; however, in the co-directional nx64 Port clock mode, X is used as a co-directional transmit clock and S is used only as receive clock. In the following section the clock which can be selected by the clock mode is denoted as "transmit clock".

The clock mode determines in most cases, whether the transmitting clock is co-directional (it has the same direction as the transmit data, i.e. it is an input signal) or contra-directional (it has the contrary direction of the transmitting data. i.e. it is an output signal).

Following clock modes are possible:

- nx64 Port: The transmitting clock is the co-directional clock coming from the equipment connected to the nx64 port (circuit 113, X).
- E1 Port: The transmitting clock is generated by the transmit clock used at the E1 port. The 2048kHz E1 clock is fractionally synthesized to the bit rate configured and available at the contra-directional transmit clock output (circuit 114). This clock mode should be used for multiservice operation (simultaneous use of E1 and nx64 kbit/s).
- Internal: The transmitting clock is generated from the internal reference clock (contra-directional, circuit 114).

- Remote: The transmitting clock is the recovered remote clock, i.e. the same clock as the receiving clock (115) at the V.35 and V.36 interface (contra-directional, circuit 114).

The clock mode to be used depends on the individual network configuration:

- nx64 kbit/s - nx64 kbit/s connection: First, it should be checked whether the equipment connected to the nx64 port uses a transmitting clock output or input. In the first case, the co-directional nx64 port mode can be used. In the latter case, one of the contra-directional clock modes should be used. The internal clock mode should be suitable in most cases, the remote clock can be used if the receive and transmit clocks have to be equal. As the contra-directional X.21 clock modes use only one clock, these configurations are possible: nx64 port - nx64 port, nx64 port - remote, internal - remote.
- nx64 kbit/s - E1 connection: The clock mode can be selected as in the previous case.

It is recommended to have at least one clock reference. So one should not use remote clock mode at both ends. You should not choose remote clock mode either if the remote modem is E1 and the E1 equipment connected to the remote E1 port uses loop timing (i.e. it uses the received clock as transmit clock).

3.4.11 Clock Direction

For V.35 and V.36 interface types, the clock direction can be configured by the user. If codirectional, Transmit Data 103 is sampled with Transmit Clock 113. If contradirectional, Transmit Data 103 is sampled with Transmit Clock 114. It is recommended to use codirectional transmit timing whenever possible, in particular for bit rates > 32 x 64 kbit/s.

3.5 Time Slot Mapping

Generally, the user interface time slots are mapped onto the DSL frame according to ETSI TS 101 524. The time slots of the user interfaces are linearly mapped to the B-channels of the DSL and vice versa. The number of time slots n from the user interface(s) must be less or equal the number of B-channels (N). Unused B-channels are filled with all ones. After startup, the complete mapping information of the units is mutually exchanged and used to set up the demapping of the time slots.

Additionally, special mapping modes can be selected by configuration in order to make best use of the available DSL bandwidth for the respective application.

3.5.1 E1 to frE1 Time Slot Mapping

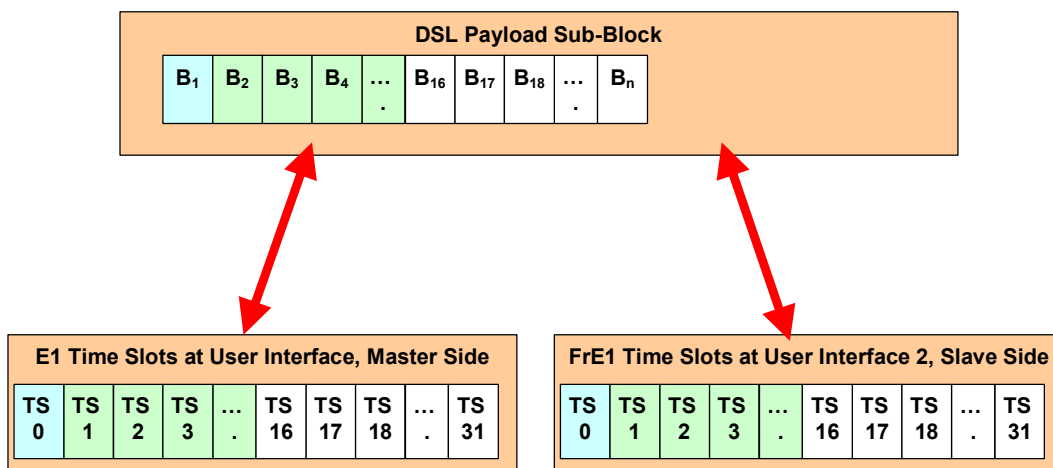

Figure 3-9: Time Slot Mapping: 16 frE1 Time Slots to E1

3.5.2 nx64 kbit/s to nx64 kbit/s Time Slot Mapping

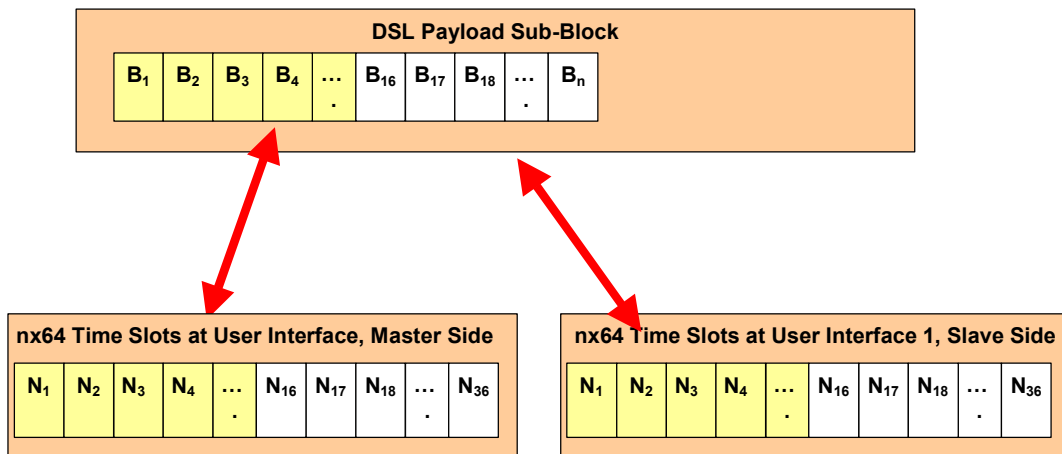

Figure 3-10: Time Slot Mapping: 16 nx64 Time Slots to nx64

3.5.3 E1 to nx64 kbit/s/Ethernet Time Slot Mapping

A mixed mode connection is a link between a modem using an E1/PRA interface and a modem using an nx64 kbit/s.

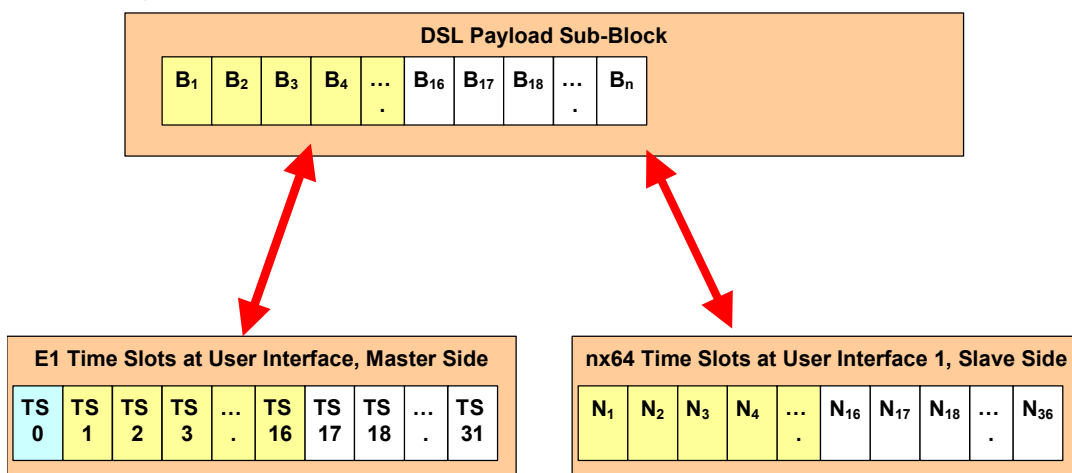

Figure 3-11: Time Slot mapping: 16 nx64 Time Slots to E1

3.5.4 E1 to E1 & nx64 kbit/s Multiservice Time Slot Mapping

When both E1 and nx64 kbit/s interface are equipped, they can be used concurrently. The available DSL bandwidth is then shared between the m time slots of the E1 interface and the n time slots of the nx64 kbit/s interface.

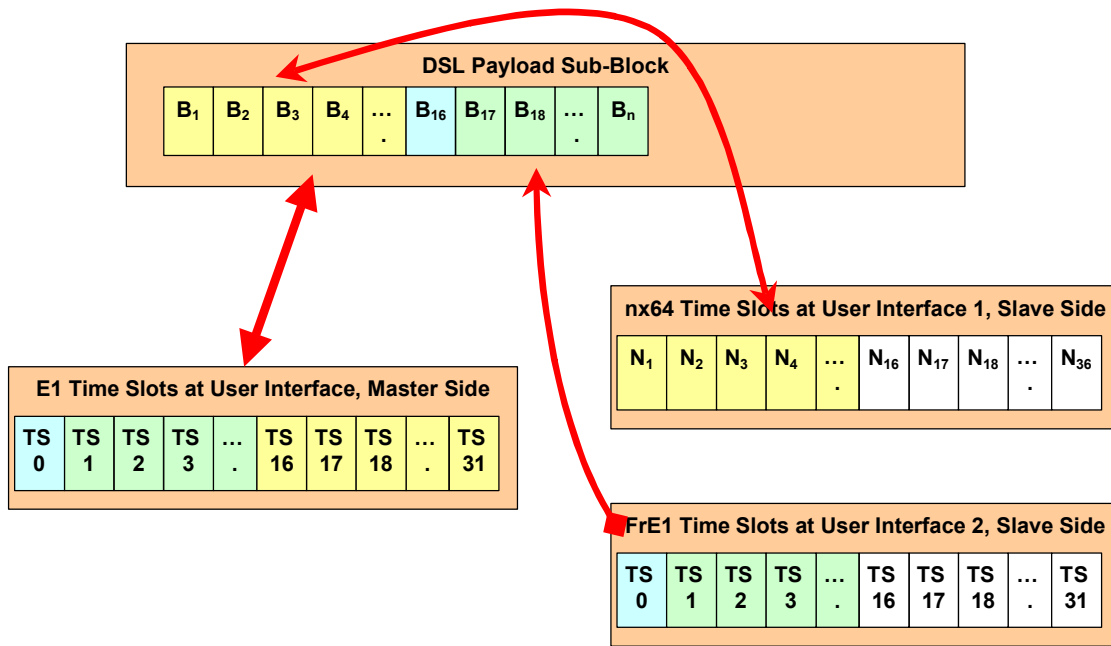

Figure 3-12: Time Slot mapping: 16 nx64 Time Slots and 16 frE1 Time Slots to E1

3.5.5 Time Slot Mapping Overview

Application	Mapping Rules	Mode 0	Mode 1	Mode 2	Mode 3
transparent E1-E1	Unaligned D2048S mode, arbitrarily but fixed mapping to DSL				
framed E1-E1	Aligned D2048S mode				
framed E1- frE1	Aligned fractional D2048S mode	TS0 not transmitted, TS16 only if frE1 ≥ 16	TS0 always transmitted, TS16 only if frE1 > 16	TS0 not transmitted, TS16 always transmitted	TS0 & TS16 always transmitted

framed PRA - frE1	Aligned fractional D2048S mode				TS0 & TS16 always transmitted
transparent E1 - nx64	Unaligned D2048S mode, n = 32				
framed E1 - nx64	Aligned fractional D2048S mode	TS0 not transmitted, TS16 only if frE1 >= 16			
framed E1- frE1 & nx64	Aligned fractional D2048S mode	TS0 not transmitted, TS16 only if frE1 >= 16	TS0 always transmitted, TS16 only if frE1 > 16	TS0 not transmitted, TS16 always transmitted	TS0 & TS16 always transmitted
nx64 - nx64	Aligned fractional D2048S mode for n<32 Unaligned D2048S mode for n=32				

Table 3-2: Time slot mapping overview

Notes: Mapping rules & configuration apply for LTU & NTU *separately!*
Shaded areas: mapping mode determined by application

3.6 TMN Interface (Minirack LTU only)

The Telecommunication Management Network (TMN) is connecting the Management Center (MC), Agent Elements (AEs) and Modems. Towards the MC the network is based on a X.25 or a LAN connection. Between AE and modems this network is established by means of a serial, asynchronous bus with differential (balanced) line transmission according to TIA/EIA-485 standard. Independent if the bus is set-up by a 2- or 4-wire connection the bus communication between Common Management Unit (CMU) and the Line Termination Units (LTUs) is always operating in half-duplex mode. The CMU is representing the Agent Element and is working as bus master on the EIA-485 side. The LTUs are representing the modem and work as bus slaves on the EIA-485 side.

3.6.1 TIA/EIA-485 4-wire Bus

The default TMN communication between *Minirack* versions of CMU and LTU is using a 4-wire transmission with different pairs for receive and transmit direction.

This bus system requires a crossing of RX and TX signals between CMU and LTU.

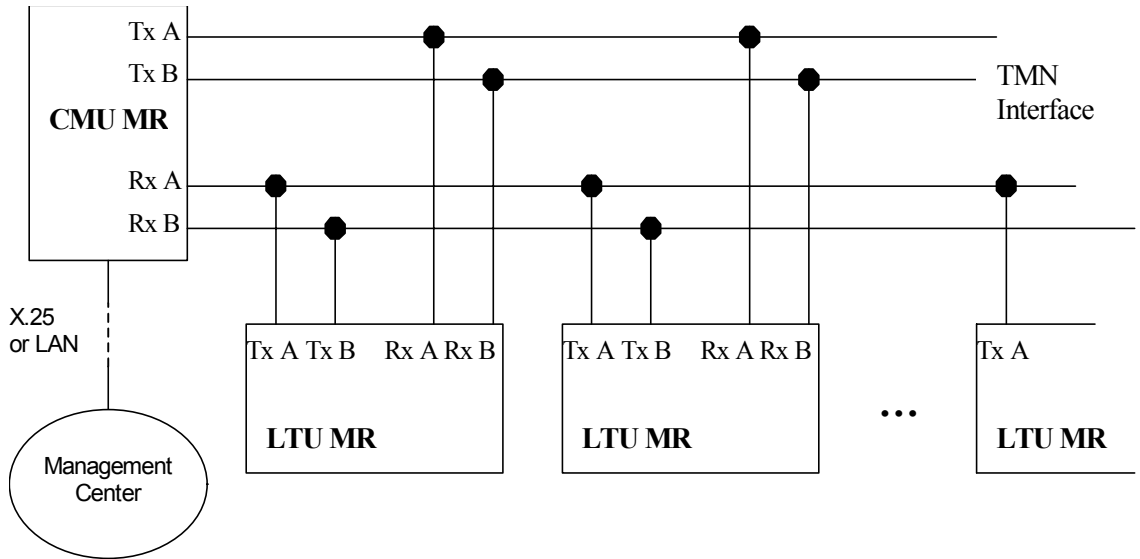

Figure 3-13: TMN Bus 4-Wire Connection for Minirack Units

3.6.2 TIA/EIA-485 2-wire Bus

TMN communication can be established via an EIA-485 2-wire connection as well. In this case no crossing of signals between CMU and LTU is required.

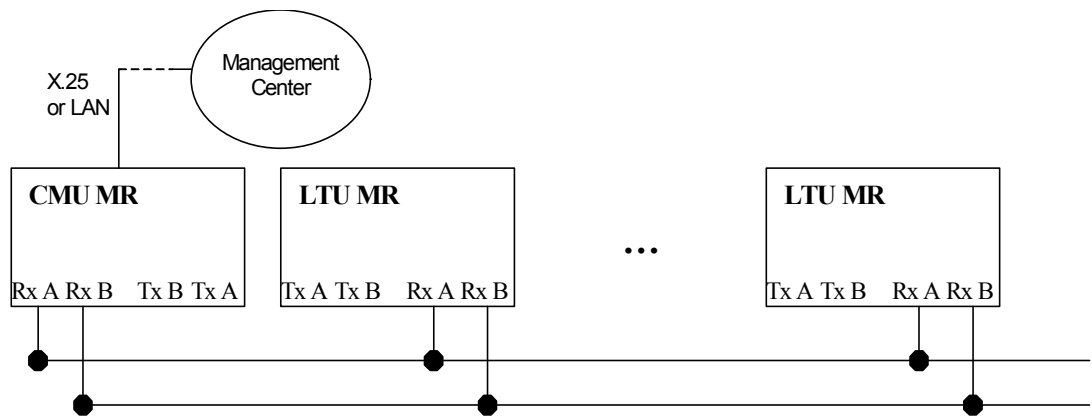

Figure 3-14: TMN Bus 2-Wire Connection for Minirack Units

A Plug-in version of the CMU is available as well. Due to the fact maximum 32 units can be connected to an EIA-485 bus, 1 CMU is able to handle more than the 12 LTUs located in one subrack. The extension of the TMN bus in the backplane towards a second subrack is realized by means of the Alarm Control Unit (ACU).

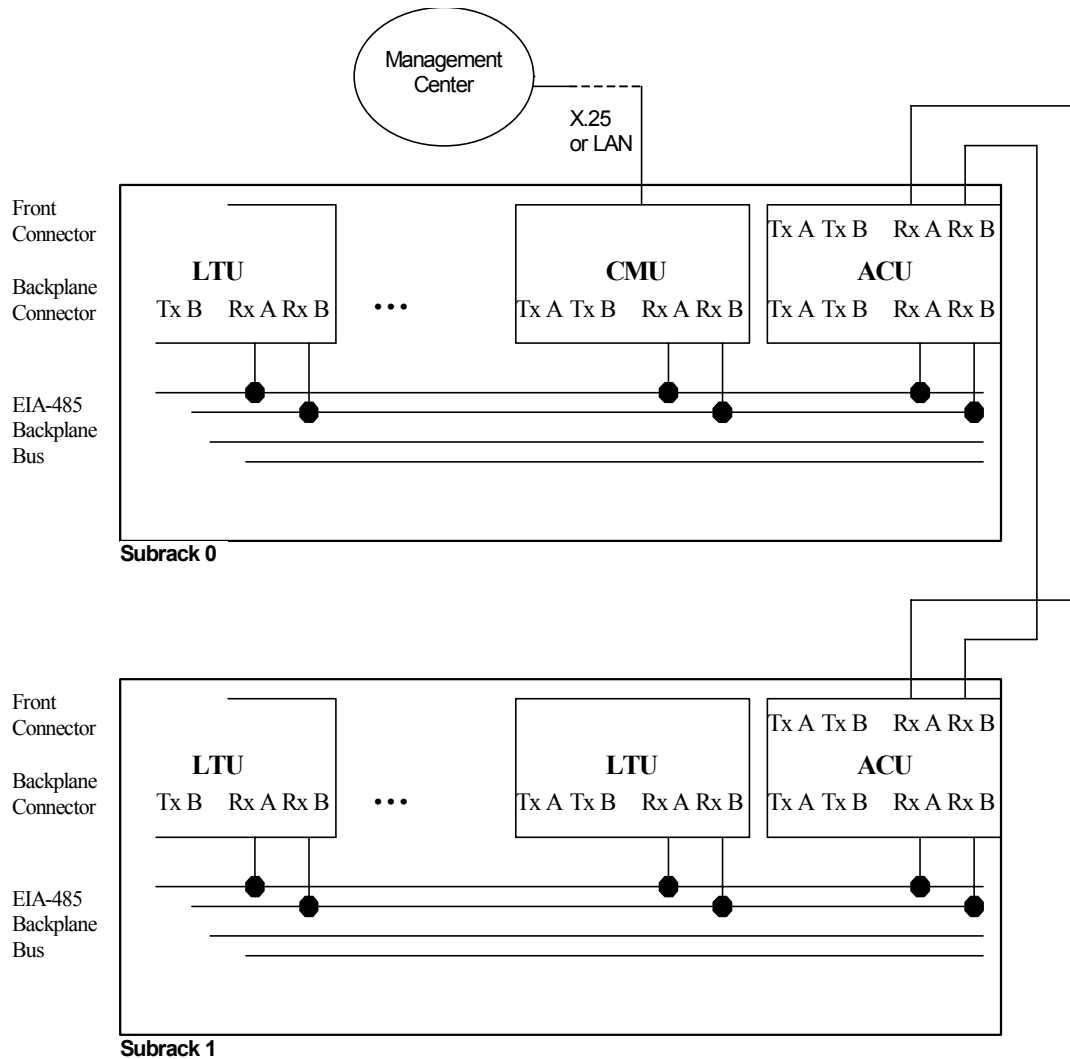

Figure 3-15: TMN Bus 2-Wire Connection for Plug-in Units

Limitation: Plug-in versions of CMU, ACU and LTU support 2-wire connection only

In case of a single subrack configuration and if no external alarm indications have to be controlled, an ACU is not needed in the subrack. But direct access for configuration of LTUs via the monitor interface on a local craft terminal is not possible without an ACU.

3.6.3 TIA/EIA-485 Bus Termination

In order to achieve highly reliable connections with a minimum of reflections, a termination with 120Ω is required at both ends of the bus by the TIA/EIA-485 standard.

A bus termination is not imperative when transmission is applied over short distances (< 1m) and with signaling rates $\frac{1}{4}200$ kbit/s.

The TMN bus communication is running with a signaling rate of 5 kbit/s. Due to this fact a termination is required only if TMN bus is extended via cable over long distances and especially if different reference ground levels are applied at both ends of the bus (different racks).

Plug-in versions of ACU and CMU offer jumpers to connect a simple 120 Ω parallel termination to both differential wire pairs of the TMN bus.

ACU Plug-in: Closing J4 and J5 will activate the termination.

CMU Plug-in: Closing jumper ST4 and ST5 will activate the termination.

More for reasons of avoiding excessive ground currents than for signal quality, the grounding configuration for the signal return path shown in Figure 3-16 is recommended for a TMN bus connections with different ground levels at both ends.

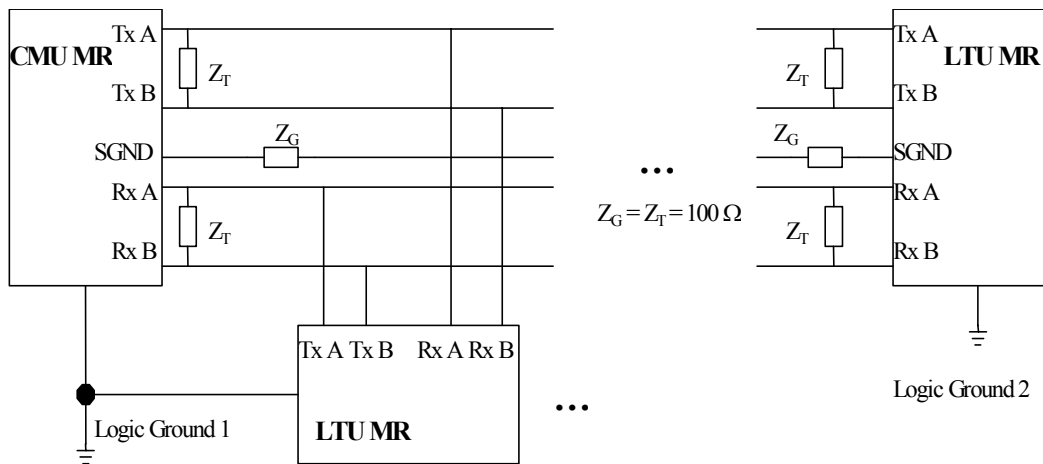

Figure 3-16: Termination for Long TMN Bus

4 Performance Monitoring

The transmission performance of a DSL link can be monitored in two different ways. The DSL signal quality is typically used during installation and maintenance procedures, whereas the G.826 error performance parameters are intended to be used for long term evaluation of an operating DSL link. Refer also to the "SQ" and "G826" monitor commands described in the "Monitor Operation" chapter.

4.1 Noise Margin SNR

The Noise Margin (NM) provides **qualitative** performance of a specific loop and is an effective maintenance tool to determine inadequate or bad cable pairs.

A NM of 0dB, in presence of Gaussian noise would yield an expected Bit-Error-Ratio of 10^{-7} .

4.2 G.826 Performance Monitoring

The G.826 error performance parameters provide **quantitative** performance information of a specific loop. They are intended to be used for long-term evaluation of operating DSL links.

The evaluation of the G.826 error performance parameters is based on CRC (Cyclic Redundancy Check) error detection: The estimation of a **bit-error rate** is not within the scope of the G.826 calculations.

4.2.1 DSL Interface

On the DSL side, six CRC6 check bits are generated per DSL frame for each channel and direction.

The software counting block errors and evaluating the error performance according to ITU-T G.826 of the respective DSL channel is using these CRC6 bits.

4.2.2 E1 Interface

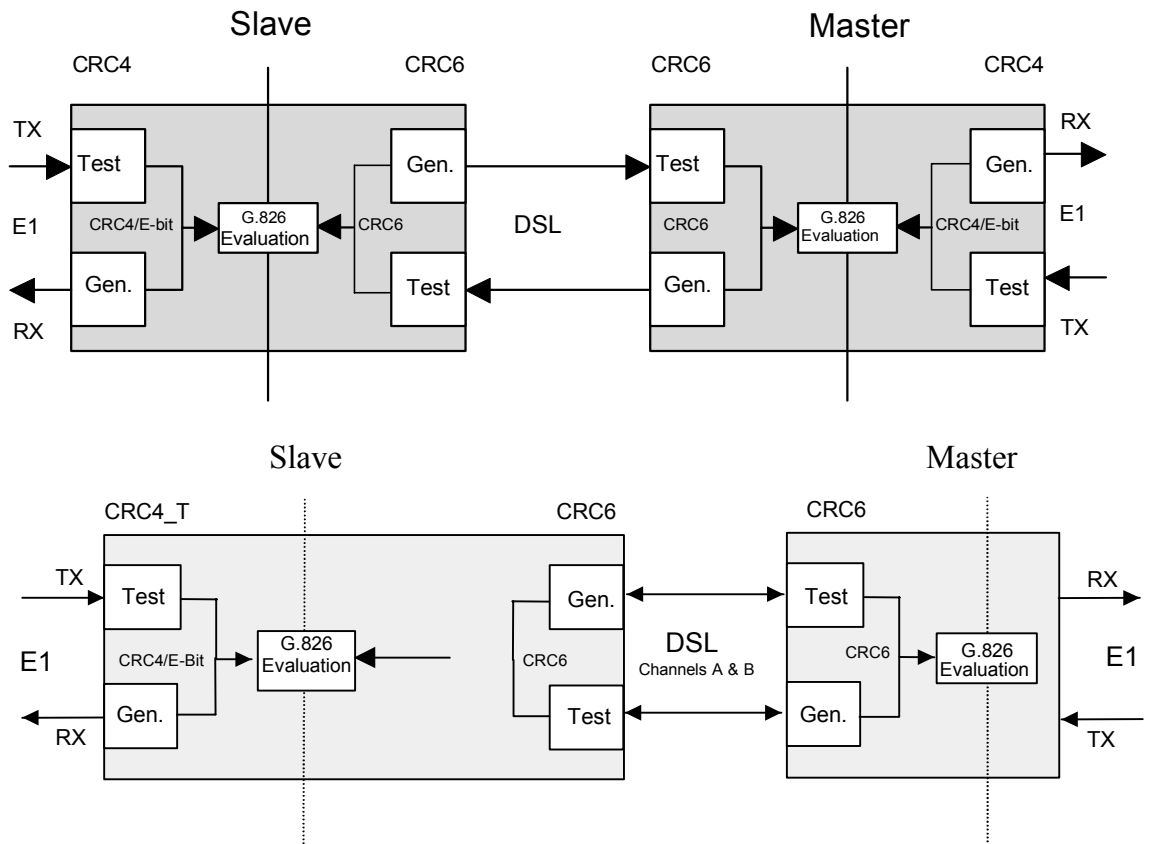

Figure 4-1: E1 G.826 Performance Evaluation

On the E1 side, four CRC4 check bits are generated per sub-multiframe (SMF) and compared with the corresponding CRC4 bits in the following SMF. If they do not match, the CRC4 error counter is incremented. The opposite station is informed of detected CRC4 errors by setting E-bits in the transmitted frames. At the same time, the E-Bits from the opposite station are counted and can be used for performance monitoring.

For the E1 interface, calculations according to G.826 are only possible in framed mode with CRC4 option enabled. In framed mode with CRC4 option disabled only FAS-errors are detected.

4.2.3 ISDN PRA Interface

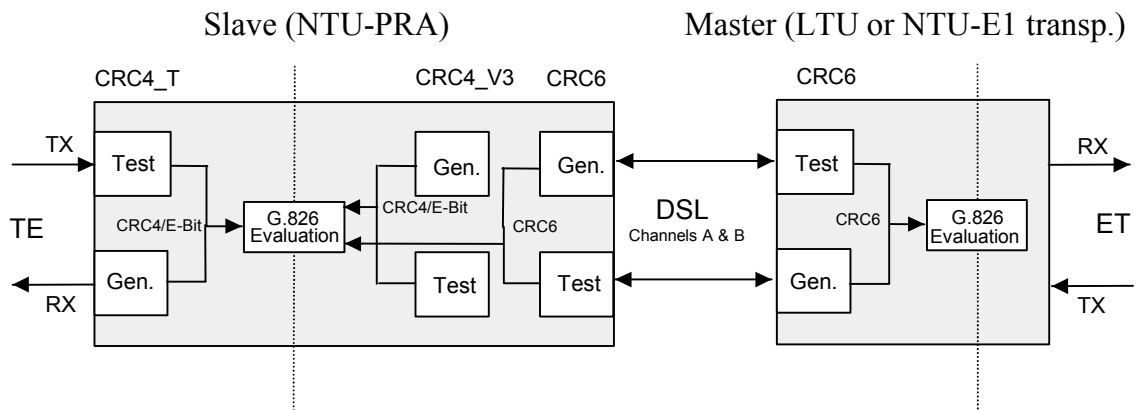

Figure 4-2: PRA G.826 Performance Evaluation

When the PRA interface is working with CRC4 processing or monitoring (options 2 and 4) four CRC4 check bits are generated per sub-multiframe (SMF) received from the ET and the NT2/TE and compared with the corresponding CRC4 bits in the following SMF. If they do not match, the corresponding CRC4 error counter is incremented. At the same time, the E-Bits from the ET and the NT2/TE are counted and can be used for performance monitoring.

For the PRA interface, calculations according to G.826 are only possible when CRC4 processing or monitoring is selected.

5 Alarms

5.1 LEDs

The two LEDs 'Status Local' and 'Status Remote' are used to display normal operation condition and alarm condition. Each LED can be green, amber, or red according to the following table.

On the Dual LTU, the LEDs are numbered from 1 to 4 and have the following functions:

<i>LED Number</i>	<i>System</i>	<i>Local / Remote</i>
1	1	Local
2	1	Remote
3	2	Local
4	2	Remote

Table 5-1: LED indication

5.1.1 Status LEDs

<i>Status</i>	<i>Local LED</i>	<i>Remote LED</i>
Power failure	off	off
Hardware / Software failure	blinking red	off
Normal operation (Master)	green	green
Normal operation (Slave)	green	off
Non-urgent alarms (local / remote)	amber	amber (off for Slave)
Urgent alarms (local / remote)	red	red (off for Slave)

Table 5-2: Alarm LED function

During Firmware Download, the Status LEDs are used as follows:

<i>Download Status</i>	<i>Local LED</i>	<i>Remote LED</i>
Local download Flash erase	blinking red	off
Local download ready	blinking amber	off
Local download in progress	blinking green	off
Remote download ready (LTU)	blinking amber	blinking amber
Remote download in progress (LTU)	blinking green	blinking green
Remote download Flash erase (NTU)	blinking red	off
Remote download ready (NTU)	blinking amber	off
Remote download in progress (NTU)	blinking green	off

Table 5-3: LED indication during firmware download

5.1.2 Alarm Conditions

5.1.2.1 Local LED

An alarm condition is displayed with the Local LED if one of the following conditions occurs:

Urgent alarm (red):

- Hardware or software failure (blinking)
- Loss of signal / frame alignment on the DSL side (LOSW)
- DSL block-error-rate according G.826 $\geq 30\%$ (BER-H)
- LTU only: overcurrent detected in remote power feeding circuit (CLD)

Non-urgent alarm (amber):

- DSL block-error-rate according G.826 $> 15\%$ (BER-L)
- Either Loop 1, Loop 2, Analog Loopback, or the Regenerator Loopback is active (LOOP1, LOOP2, ALB, LOOPREG, BERT)
- Alarm cut off is activated (ACO)

E1 Interface:

- Loss of signal or frame alignment on the E1 side (LOS-S, LFA-S)
- Loss of external clock (EXT-LOC, in external clock mode only)
- Receiving AIS on E1 side (AIS-S)
- Excessive block error rate on E1 side (BER-S)

PRA Interface:

- Loss of signal at the T reference point (LOS-S)
- Loss of frame at the T reference point (LFA-S)
- Receiving AIS at the T reference point (AIS-S)
- Loss of frame at the V3 reference point (LFA-V3)

- Receiving AIS at the V3 reference point (AIS-V3)

nx64 kbit/s Interface:

- Loss of codirectional clock or clock rate mismatch (clock mode: nx64 Port) on the nx64 kbit/s side (LOC),
- Data Terminal Ready (DTR, circuit 108/2) on the nx64 Port is detected as 'OFF'. For X.21, the control-signal (C) is represented by DTR.
- The loops 1 and 2 can be controlled by the circuits 140 (RL) and 141 (LL), thus the alarms LOOP1 and LOOP2 can also be caused by the nx64 kbit/s interface

Displaying an urgent alarm has a higher priority than displaying a non-urgent one, i.e. an amber alarm will be "overwritten" by a red alarm.

5.1.2.2 Remote LED

The remote LED is an image of the local LED of the remote slave station (see previous LED-table for exceptions). When configured as "slave" no remote access is possible, so the remote LED is turned off.

5.2 Alarm Relays

5.2.1 LTU

There are two concepts for signaling the alarm status of the LTU in the subrack.

Each LTU has an open collector alarm output working on a common signaling line. The ACU2R gives consolidated alarm signals to the sum alarm relays "Urgent" and "Non-urgent".

The alarm status is also analyzed by the ACU48R via the internal monitor bus to poll each of the possible 24 (=12 dual) LTUs within the subrack and to signal the alarm status to two alarm relays "Urgent" and "Non-urgent" specific for each LTU.

Under normal LTU power conditions the two output stages of each LTU are controlled by its microcontroller. In case of a power failure on an LTU, both the "Urgent" and "Non-urgent" alarms will be activated on the ACU. (The ACU generates an auxiliary +5 V_{DC} which is used to pull-up the open collector alarm output stages of the LTUs.)

5.2.1.1 Alarm Conditions

Urgent Alarm:

- At least one of the LTU – LEDs displays a red alarm
- Power failure of any one of the LTUs
- Power failure of the auxiliary +5V_{DC} auxiliary supply on the ACU
- Power failure of both –48V_{DC} supplies

Non-urgent Alarm:

- At least one of the LTU – LEDs displays an amber alarm and none of the LTU – LEDs displays a red alarm
- Power failure of any one of the LTUs
- Power failure of the auxiliary +5V_{DC} auxiliary supply on the ACU
- Power failure of one of the –48 V_{DC} supplies

5.2.2 NTU

The two alarm relays “Urgent” and “Non-urgent” are located on the NTU, the alarm contacts are available on the monitor connector.

5.2.2.1 Alarm Conditions

Urgent Alarm:

- At least one of the NTU - LEDs is red

Non-urgent Alarm:

- At least one of the NTU - LEDs is amber and none of the NTU - LEDs is red

Note: In case of remote power the alarm relays are kept inactive to save power

Note: If alarm cut off is activated (ACO = on), the alarm relays are disabled.

5.3 Alarm Display in Monitor Menus

Actual alarm status and alarm history can be displayed on a terminal or a PC with terminal emulation connected to the Monitor interface.

The Alarm Menu display within the Fault and Maintenance Management Menu shows up the actual alarm status of the device.

The Alarm Trace presents a note about each alarm change on the terminal.

The Alarm History, available only on LTUs, displays the alarm message and a time stamp. A maximum of 128 alarms is stored per DSL link in the RAM of the LTU. The time stamp for an event is calculated on basis of the internal system time.

Note: Each power-on or system reset will restart the internal system time and will clear the event log of the alarm history.

6 Power Concept

6.1 LTU

6.1.1 Power and Grounding

Each plug-in LTU is fed via subrack backplane with (dual) $-48V_{DC}$ (referenced to $0V_{DC}$ of the exchange battery), whereas the minirack LTU is fed via an internal power supply unit. The LTU generates the used voltages onboard.

The ground reference of all voltages on the secondary side of the LTU's DC/DC-converter is tied to FPE (Functional Protective Earth).

Additionally, the plug-in LTU is fed over the backplane with an auxiliary $+5V_{DC}$ supply (referenced to ground) generated on the ACU. The only purpose of this voltage is to drive the alarm circuitry on each LTU, even in the case of a failure of the LTU's onboard DC/DC-converter.

In case of a failure of the LTU's onboard power supply, both LEDs on the front panel will be extinguished.

6.2 NTU

6.2.1 Power and Grounding

The ground of an NTU is typically floating when referenced to earth. If an NTU is equipped with an E1 or nx64 kbit/s user interface, the shields / signal ground of the cables are coupled to the ground of the NTU.

A slide switch located on the rear side of the housing can select powering of the NTU unit:

- Remote powering from the LTU over the DSL line or
- Local powering by an external AC/DC or DC/DC adapter

The position of the switch can be changed by means of a small screwdriver. Before operating the switch, the DSL line connector and the mains adapter connector should be removed.

The supply voltage input is protected against reversal of polarity but *not fused*. Appropriate fusing has to be done externally. AC/DC adapters from SZ are recommended.

Caution: A $48V_{DC}$ battery supply must not be connected directly to the "AC/DC adapter" connector! High voltage transients from the DSL line may damage other equipment connected to the battery. A DC/DC converter with 4kV transient isolation voltage should be used in this case.

6.2.2 Power Failure Alarm

The power supply bit **ps** is used to indicate the status of the local power supply in the NTU. The power status bit is set to ONE if power is normal and to ZERO if the power has failed; On loss of power at the NTU, there is enough power left to communicate three "Power Loss" messages towards the LTU. In case of a failure of the NTU's power supply, both LEDs will be extinguished.

6.3 Remote Powering

Remote power feeding is supported. The remote NTU-R can be fully powered over the DSL twisted wire-pairs from the LTU-R. The remote power-feeding concept has the following characteristics:

- Per pair remote feeding (no "phantom" -circuit)
- Cross-wiring tolerant
- Power feeding voltage within limits of TS 101 524 (max. $112V_{DC}$)
- Independent current limiters on a per pair basis (microcontroller - controlled)
- Tolerant against micro-interruptions
- Automatic system restart after power failure

The remote power voltage of $111V_{DC}$ is generated locally on each LTU-R and is referenced to earth. In case of overvoltage ($|U| > 118V_{DC}$), the unit is immediately shutdown within 100ms and can be reactivated only after an interruption of at least 500ms of its $-48V_{DC}$ supply / supplies. The LTU is able to feed up to $56\pm 3mA_{DC}$ over each DSL pair.

The ability of providing remote power to the DSL line can be permanently switched off by setting the R/L jumpers located on the PCB in position "RPWR OFF". In this case, the DSL line interface is disconnected from the remote power circuitry and it behaves like the DSL interface of a NTU, i.e. it is floating.

Caution: If changing the remote powering condition the LTU must not be connected to the power supply. For the LTU in minirack the external power supply must be disconnected first before opening the cover!

Remote powering depends strongly on the power consumption of the NTU (which in turn depends slightly on the supply voltage) as well as the loop resistance (wire diameter and cable length).

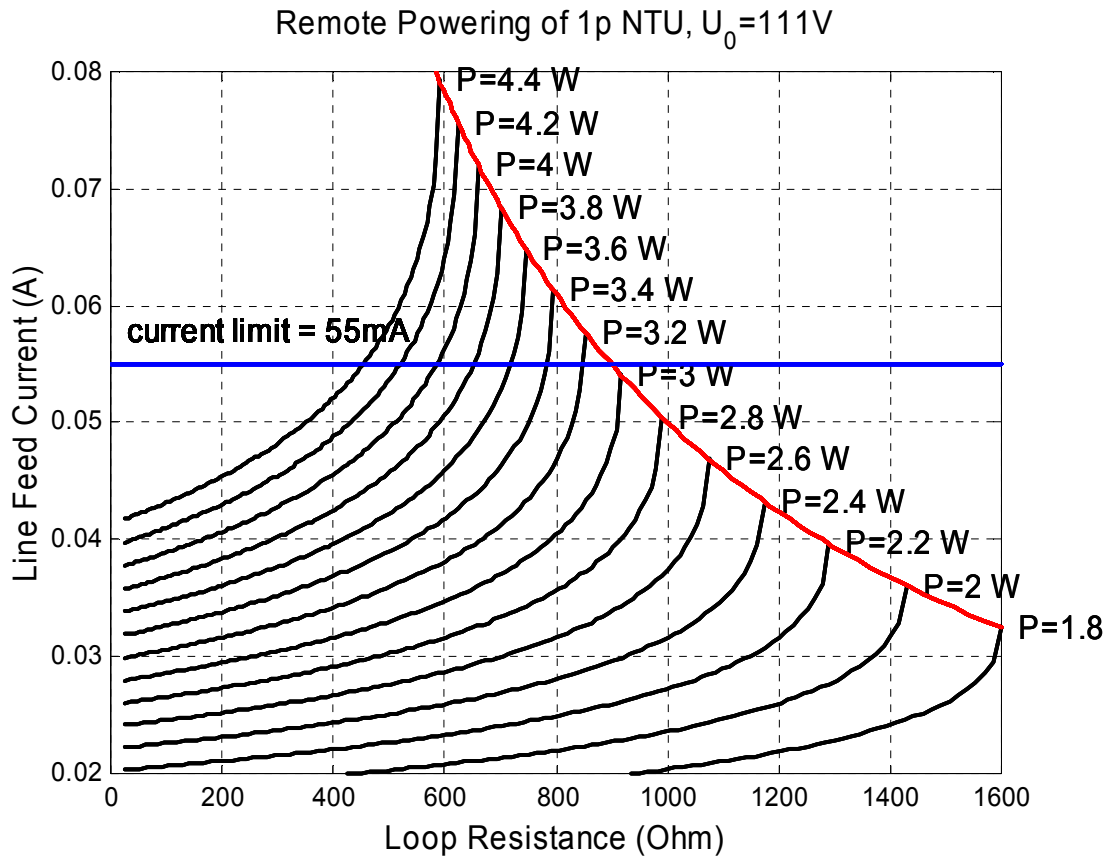

Figure 6-1: Line feed current vs loop resistance for different NTU power consumptions

7 Monitor

7.1 General

The units can be connected to a terminal or a PC with a terminal emulation in order to monitor relevant events and to display additional information such as signal quality of the DSL link or the G.826 error performance parameters. In addition, full system configuration and fault localization can be done over the monitor interface.

The terminal for monitoring should be VT100 compatible and be configured as follows:

- 9600 baud, asynchronous
- 8 bits, no parity, one stop bit
- XON/XOFF enabled
- No new line on carriage return (i.e. no line feed on carriage return)

7.2 Addressing

7.2.1 LTU

There is a point / multipoint TTL-bus (9600 baud) on the subrack's backplane. The TTL to RS-232 level conversion is done on the ACU where the monitor connector is located.

In order to re-enable communication of LTUs occasionally left in XOFF state, it is recommended to start each session with Ctrl-Q (=XON) followed by an ECHO command.

At any time, only one of the LTUs in the subrack can be logically connected to the monitor interface. The appropriate LTU interface is addressed (i.e. selected) according to its physical position in the subrack, starting with the leftmost slot number 01 and ascending rightwards to number 12. If one LTU supports a second interface, it may be addressed by adding 12 to the address of the first interface.

To select the first interface on the LTU in slot number **SN**, just type "**%SN**" at the terminal, even in the case it does not show any prompt. (e.g. to select the LTU in slot 01, type "%01"). To select the second interface (optional) in the same slot number, just type "**%(SN+12)**" at the terminal.

Single LTU Interface Addressing Scheme

Unit	LTU	LTU	LTU	LTU	LTU	LTU	LTU	LTU	LTU	LTU	LTU	LTU	ACU	PSB
First Interface Address	01	02	03	04	05	06	07	08	09	10	11	12	ACU	

Subrack

Dual LTU Interface Addressing Scheme

Unit	LTU	LTU	LTU	LTU	LTU	LTU	LTU	LTU	LTU	LTU	LTU	LTU	ACU	PSB
First Interface Address	01	02	03	04	05	06	07	08	09	10	11	12	ACU	
Second Interface Address	13	14	15	16	17	18	19	20	21	22	23	24		

Subrack

Multipoint LTU Interface Addressing Scheme

Unit	LTU	LTU	LTU	LTU	LTU	LTU	LTU	LTU	LTU	LTU	LTU	LTU	ACU	PSB
First Interface Address	01	02	03	04	05	06	07	08	09	10	11	12	ACU	
Second Interface Address	13	14	15	16	17	18	19	20	21	22	23	24		
Third Interface Address	25	26	27	28	29	30	31	32	33	34	35	36		
Fourth Interface Address	37	38	39	40	41	42	43	44	45	46	47	48		

Subrack

Figure 7-1: LTU Interface Addressing Scheme

To see which units in a rack are available, you can use the "ECHO" command. Each present unit will respond with its associated slot number (%SN).

The response could be: %01 %03 %08 %10 %11 %12 %15

Note: Each command must be terminated by a carriage return.

7.2.2 LTU Minirack

For Minirack versions of the LTU, the address number of the DSL interface can be set manually by monitor commands in the Configuration Management (CM) menu. After power-up of a Minirack LTU the local monitor main menu appears always with the first DSL system activated (behaviour like a NTU).

Address numbers in range 1-127 can be set independently to the different DSL systems of a LTU.

7.2.3 NTU

There is no need of addressing for a point-to-point connection.

For Multipoint Operation see the corresponding chapter

7.3 Structure and Organization

The structure and organization of the monitor menu is adapted to ITU-T M.3400 for TMN with its five sub-sets.

<i>Sub-set</i>	<i>Short-form</i>
Performance management	PM
Fault and maintenance management	FMM
Configuration management	CM
Accounting management	AM
Security and remote management	SM

Since accounting management is not supported, AM is not in the monitor's main menu.

```

                        Watson V SHDSL
                    E1 Monitor V1.3 Dual
Copyright (C) 2001 by Schmid Telecom AG Zuerich, Switzerland

```

```

+-----+
|           Main Menu           |
+-----+

```

1. Performance management (PM)
2. Fault and maintenance management (FMM)
3. Configuration management (CM)
4. Security and remote management (SM)
5. Exit
- N. Next sub-system

```
LTU_10> Select [1..5,N]:
```

To select the desired sub-menu, type the appropriate number.

Notes:

The "Exit" command, number 5, is only available on the LTU. To address another LTU, type "**%SN**".

Periodic displays (DIAGNOSTIC, G.826, BERT) are automatically stopp displaying the information but continuing collecting information in the background upon receiving commands generating displays with more than one line. (e.g. CONFIG, STATUS, ALARM, READBER, etc.)

The 'Next sub-system' command, N, addresses monitoring the next subsystem. It is only available on the LTUs with more than one system.

7.3.1 Available Shortcuts for Commands

For easier use of the available commands some shorts-cuts have been introduced.

<i>Command</i>	<i>Short-Cut</i>
DIAGNOSTIC	DIA
CONNECT	CON
DISCONNECT	DIS

Table 7-1: Command Shortcuts

7.3.2 Performance Management PM

03:33:10 Performance management activated
type <M> to return to MAIN, or <H> for HELP information

Type <H> and the monitor lists all available commands in the performance sub-menu:

Performance management activated
type <M> to return to MAIN, or <H> for HELP information

```

LTU_01_PM> H
~~~~~
G826                Display local SHDSL G.826 parameter
G826 C              Display local SHDSL G.826 parameter continuously
G826 E1            Display local E1 G.826 parameter
G826 E1 C          Display local E1 G.826 parameter continuously
RESETG826          Reset G.826 error performance parameter
STARTBER m dir p   Start BER test for m minutes dir=[0..3] p=[0,1])
STOPBER            Stop BER test
READBER            Display results of BER test
READBER C          Display results of BER test continuously
RESETBER           Reset BER counters
M(AIN)             Return to main menu
~~~~~

```

7.3.2.1 G826 Command

The G826 command displays the ITU-T G.826 error performance parameters on the DSL line side of the local and remote DSL unit:

```

LTU_01_PM> G826
~~~~~
G.826 Error Performance :   CRC6 A
~~~~~
Errored blocks          : 00000000
Errored seconds         : 00000000
Severely errored seconds : 00000000
ESR [%]                 : 0.00
SESR [%]                : 0.00
BBER [%]                : 0.00
Available time          : 00624483
Unavailable time        : 00000024

```

```
~~~~~
LTU_01_PM>
```

Definitions:

1. CRC6: Cyclic redundancy check indicating errored blocks, are being received on the local DSL side.
2. Errored block (EB): A block in which one or more bits are in error.
3. Errored seconds (ES): A one second period with one or more errored blocks. SES defined below is a subset of ES.
4. Severely errored second (SES): A one second period which contains $\geq 30\%$ errored blocks.
5. Background block error (BBE): An errored block not occurring as part of an SES.
6. Errored second ratio (ESR): The ratio of ES to total seconds in available time during a fixed measurement interval.
7. Severely errored second ratio SESR: The ratio of SES to total seconds in available time during a fixed measurement interval.
8. Background block error ratio (BBER): The ratio of errored blocks to total blocks during a fixed measurement interval, excluding all blocks during SES and unavailable time.

Options:

- C:* Updates the G.826 parameters continuously
- E1:* The G826 E1 command displays the ITU-T G.826 error performance parameters on the E1 2Mbit/s side. This command is only available if framed mode is enabled.

If CRC4 mode is on, the following parameters are displayed:

```
LTU_01_PM> G826 E1
~~~~~
G.826 Error Performance :      CRC4      E-Bit
~~~~~
Errored Blocks          : 00000000 00000000
Errored seconds         : 00000000 00000000
Severely errored seconds : 00000000 00000000
ESR [%]                 :      0.00      0.00
SESR [%]                :      0.00      0.00
BBER [%]                :      0.00      0.00
Available time          : 00524129 00524129
Unavailable time        : 00000024 00000024
~~~~~
LTU_01_PM>
```

If CRC4 mode is off, the following parameters are displayed:

```
LTU_01_PM> G826 E1
~~~~~
G.826 Error Performance :      FAS
~~~~~
Errored blocks          : 00000000
Errored seconds         : 00000000
Severely errored seconds : 00000000
ESR [%]                 :      0.00
SESR [%]                :      0.00
BBER [%]                :      0.00
Available time          : 00009841
Unavailable time        : 00000024
~~~~~
LTU_01_PM>
```

Definitions:

1. CRC4: Cyclic redundancy check indicating errored sub-multiframes received on the local 2Mbit/s E1 side.
2. E-bit: CRC-4 indication bit denoting received errored sub-multiframes on the 2Mbit/s E1 side.
3. FAS: Errored Frame Alignment Signal received on the 2Mbit/s E1 side. The criteria for severely errored seconds (SES) is 28 FAS-Errors per second (in accordance to G.821).

In PRA mode, the G826 E1 command displays the ITU-T G.826 error performance parameters on the PRA 2Mbit/s:

```

LTU_01_PM> G826 E1
~~~~~
G.826 Error Performance :   CRC4_T   E-Bit_T   CRC4_V3   E-Bit_V3
~~~~~
Errored Blocks          :   00000000   00000000   00000000   00000000
Errored seconds        :   00000000   00000000   00000000   00000000
Severely errored seconds :   00000000   00000000   00000000   00000000
ESR [%]                :         0.00         0.00         0.00         0.00
SESER [%]              :         0.00         0.00         0.00         0.00
BBER [%]               :         0.00         0.00         0.00         0.00
Available time         :   00524129   00524129   00524107   00524107
Unavailable time       :   00000024   00000024   00000046   00000046
~~~~~
LTU_01_PM>

```

Definitions:

1. CRC4_T: Cyclic redundancy check indicating errored sub-multiframes received at the NT1 side of the T reference.
2. E-Bit_T: CRC-4 indication bit indicating received errored sub-multiframes at the NT2/TE side of the T reference point.
3. CRC4_V3: Cyclic redundancy check indicating errored sub-multiframes received at the NT1 side of the V3 reference point.
4. E-Bit_V3: CRC-4 indication bit indicating received errored sub-multiframes at the ET side of the V3 reference point.

Note: The G826 E1 command is only available if option 2 (CRC4 processing) or option 4 (CRC4 monitoring) is selected in the configuration.

7.3.2.2 RESETG826 Command

The RESETG826 command sets the G.826 error performance parameters back to zero.

```

LTU_01_PM> RESETG826
04:35:30 G.826 error performance parameter reset
LTU_01_PM>

```

7.3.2.3 STARTBER Command

The STARTBER *m dir p* command starts the pseudo random binary sequence (PRBS) generator and bit error rate (BER) meter for a duration of *m* minutes. The test signal generator sends a

PRBS of length $2^{15}-1$ according to ITU-T 0.151 ($p = 0$) or a PRBS of length $2^{11}-1$ according to ITU-T 0.152 ($p = 1$) towards the remote modem ($dir = 0$), towards the first user interface ($dir = 1$) or towards the second user interface ($dir = 2$, Multiservice only).

Selecting $dir = 3$ will start an internal SHDSL bit error rate test which is completely independent from any user interface and configuration. Make sure that the link is running before starting the internal BER test. Also, if the SHDSL link fails during the internal BER test, the test must be restarted after the link has been re-established.

When no parameter is specified, the default values are $m = 24$ hours, $dir = 0$ and $p = 0$.

Before starting a BER test with $dir = 0$, a loopback should be established at the SHDSL side (analog loopback, regenerator loopback or remote loopback 2).

To test also the user interface of the remote equipment, a hardware loopback at the remote user interface (connection of transmit and receive signals) is possible too.

The test will be stopped automatically after m minutes; a manual stop is possible with the STOPBER command. The results of the BER test can be displayed by the READBER command.

```
LTU_01_PM>STARTBER 3
~~~~~
BER Test Results                                     Test running
~~~~~
Test direction      :      SHDSL
Test interval       :         180
Test pattern        :      2^15-1
Test bit rate       :     1984000
Bit errors          :           0
Bit error rate      :     0.00E+00
Sync loss seconds  :           0
Elapsed seconds     :           6
~~~~~
LTU_01_PM>
```

7.3.2.4 STOPBER Command

A BER test can be manually terminated by this command.

```
LTU_01_PM> STOPBER
29:01:30 BER test stopped
LTU_01_PM>
```

7.3.2.5 READBER Command

The results of a BER test can be displayed using this command. When a test is running, the current results are displayed, when no test is running, the results of the last BER test are displayed.

```
LTU_01_PM> READBER
~~~~~
BER Test Results                                     Test completed
~~~~~
Test direction      :      SHDSL
Test interval       :         180
Test pattern        :      2^15-1
Test bit rate       :     1984000
Bit errors          :           0
Bit error rate      :     0.00E+00
Sync loss seconds  :           0
```

```
Elapsed seconds      :          180
~~~~~
LTU_01_PM>
```

7.3.2.6 RESETBER Command

The RESETBER command resets the error and time counters of a BER test.

```
LTU_01_PM> RESETBER
29:01:30 BER counters reset
LTU_01_PM>
```

7.3.3 Fault and Maintenance Management FMM

04:41:20 Fault and maintenance management activated
type <M> to return to MAIN, or <H> for HELP information

Type <H> and the monitor lists all available commands in the fault and maintenance sub-menu:

```
LTU_10_FMM> H
~~~~~
DIAGNOSTIC (DIA)   Activate / deactivate diagnostic display
STATUS             Display local system status
ALARM              Display local alarm status
ALARM T            Turn alarm trace on/off
ALARM H hh:mm     Display alarm history (hh:mm = [0:00..23:59])
CLEAR              Clear alarm history
ACO [ON,OFF]      Activate / deactivate alarm cutoff
LOOP1 [ON,OFF]    Activate / deactivate local loopback
LOOP2 [ON,OFF]    Activate / deactivate remote loopback
LOOPREGn [ON,OFF] Activate / deactivate regenerator loopback
STARTAL           Start analog loopback
STOPAL            Stop analog loopback
TRACETIME [1..20] Change trace time (1..20 seconds)
RESET              Reset system
RESETCARD          Perform complete HW and SW reset
M(AIN)            Return to main menu
~~~~~
LTU_10_FMM>
```

7.3.3.1 DIAGNOSTIC Command

The DIAGNOSTIC command allows the user to monitor the signal quality, the G.826 parameter, the attenuation, the status and the alarms of one LTU/NTU

```
LTU_01_FMM> Diagnostic
-----+-----
Diagnostic:  SQ  G.826(ES)  Attn  Status  | Alarms
-----+-----
LTU-A:      +13.5  00000001  +00.79  Sync    | PID
LTU-B:      +14.0  00000000  +00.86  Sync    |
LTU-C:      +16.5  00000001  +00.00  Sync    |
LTU-D:      +15.0  00000000  +00.08  Sync    |
-----+-----
NTU-A:      +14.5  00000001  +00.00  Sync    |
NTU-B:      +14.0  00000000  +00.00  Sync    |
NTU-C:      +11.5  00000000  +00.02  Sync    |
NTU-D:      +11.5  00000000  +00.00  Sync    |
-----+-----
LTU_01_FMM>
```

Note: Upper window (LTU-A, LTU-B lines) contains local, lower window (NTU-A, NTU-B lines) contains remote diagnostic information

The Slave displays only local information

In case of a NTU-NTU or LTU-LTU connection, the unit designators are changed accordingly

The DIAGNOSTIC command is available at menu levels 1-4, the help information is only displayed at level 2

The DIAGNOSTIC command is READ only.

7.3.3.2 STATUS Command

The STATUS command displays the actual system status:

```

LTU_01_FMM> STATUS
~~~~~
Local System Status                                     V1.4
~~~~~
SYNC-A: 00 OPS-A: 10 PID-A: 00 PWR-A:+00.00 GAIN-A:+00.00
~~~~~
LTU_01_FMM>
    
```

Definitions:

<i>Parameter</i>	<i>Status</i>	<i>Meaning</i>
SYNC		Status of SHDSL synchronization state machine of loop A according to ETSI TS 101 524.
	00	Out of Sync State
	01	State 0
	02	In Sync State
	03	State 1
	04	State 2
	05	State 3
	06	State 4
OPS	07	State 5
		Operational mode of the transceiver
	00	Idle Mode
	01	Data Mode
	10	Startup handshake in progress
PWR	18	Startup training in progress
	80	Local analog loopback
GAIN	n	Transmit power of each channel [dBm]
PID-A	n	Receiver Gain [dB]
	n	Pair Identification when 4p operation is enabled

<i>Parameter</i>	<i>Status</i>	<i>Meaning</i>
PRA (PRA mode only)		Current state of the digital section (DS) according to ETS 300 233 section 9.4 (only the states possible in NT1 & LT mode are displayed).
	00	NTU dying
	01	NTU dying & FV3/FC5
	02	NTU dying & FC4
	03	NTU dying & FC4 & FV3/FC5
	04	NTU dying & AIS
	05	NTU dying & AIS & FC4
	06	Normal function
	07	FC4
	08	FV3/FC5
	09	FV3/FC5 & FC4
	10	Loopback 1
	11	Loopback 1 & FC4
	12	Loopback 2
	13	Loopback 2 & FC4
	14	Loopback 1 & NTU dying
	15	Loopback 1 & NTU dying & FC4
	16	Loopback 2 & NTU dying
	17	Loopback 2 & NTU dying & FC4
	18	AIS
19	AIS & FC4	

7.3.3.3 ALARM Command

The ALARM command displays the actual alarm status:

```

LTU_01_FMM> ALARM
~~~~~
Local Alarm Status
~~~~~
LOS-S:off  AIS-S:off  LOOP1:off  ACO:off  EXT-LOC:off
LFA-S:off  BER-S:off  LOOP2:off  ALB:off  LOOPREG:off
LOSW-A:off BER-A:off  SEG-A:off  CLD-A:off BERT:off
~~~~~
*** Warning: PID alarm detected - use straight pair cabling for this
           connection
~~~~~

LTU_01_FMM>

```

Options:

T Turns alarm trace on / off

Definitions:

LOS-S:	Loss of signal at subscriber (E1) side
LFA-S:	Loss of frame alignment at subscriber (E1) side
AIS-S:	AIS (Alarm Indication Signal) detected at subscriber (E1) side
BER-S:	Excessive Block Error Rate on subscriber side If CRC4 enabled : BER-S = on if more than 805 CRC4 Errors per second. If CRC4 disabled : BER-S = on if more than 28 FAS Errors per second.
EXT-LOC:	Loss of external clock
LFA-V3	Loss of frame alignment at V3-reference point (PRA mode)
AIS-V3	Alarm indication signal at V3-reference point (PRA mode)
LOSW-A	Loss of Sync Defect (LOSW defect) on channel A
LOSW-B	Loss of Sync Defect (LOSW defect) on channel B
BER-A:	SHDSL block-error-rate according G.826 \geq 30% on channel A
BER-B:	SHDSL block-error-rate according G.826 \geq 30% on channel B
LOOP1:	SHDSL test loop 1 active (see section 0)
LOOP2:	SHDSL test loop 2 active
ACO:	Alarm cutoff
ALB:	Analog loopback
SEG-A:	Segment defect alarm indication if regenerators present on channel A

SEG-B:	Segment defect alarm indication if regenerators present on channel B
LOOPREG:	Regenerator loopback active
BERT:	BER test activated
CLD-A	Current limit detection on channel A
CLD-B	Current limit detection on channel B
PID	Display a pair mismatch when operating in 4p mode (master only)

7.3.3.4 ALARM H Command

A.) Alarm H command without time adjustment.

The ALARM H command displays alarm events of the past with a time stamp based on the internal system time of the LTU. The time stamp shows the number of days elapsed and the system time in format **24-hour:minute** at the occurrence instant of the event.

This relative LTU system time is set to zero by each RESET command or power-on.

```
LTU_10_FMM> ALARM H
~~~~~
Alarm History (day:hour:min)
~~~~~
+0:00:00  LOS-S alarm on
+0:00:00  remote alarm on
+0:00:02  LOS-S alarm off
+0:00:02  remote alarm off
~~~~~End of Alarm History~~~~~
LTU_10_FMM>
```

B.) Alarm H command with time adjustment.

Additional entering of the actual time in format **24-hour:minute** when calling the ALARM H command will modify the displayed time stamp to real time representation.

On basis of the time declaration entered by the user and the LTU's internal system time, the event is marked with the number of days elapsed and the real time of the occurrence instant in format **24-hour:minute**

```
LTU_10_FMM> ALARM H 14:23
~~~~~
Alarm History (day:hour:min)
~~~~~
+0:14:18  LOS-S alarm on
+0:14:18  remote alarm on
+0:14:20  LOS-S alarm off
+0:14:20  remote alarm off
~~~~~End of Alarm History~~~~~
LTU_10_FMM>
```

Note: Power-on or RESET command will reset the internal system time and will clear all stored events. The alarm history is limited to 500 alarm messages per system / DSL link and a maximum collection time of about 240h.

The current time will be displayed in case the alarm history is empty.

Note: Once a time adjustment is made with the ALARM H command, this adjustment is stored in the LTU. Repeated ALARM H command executions without a time adjustment will still display time stamps calculated on basis of the time declaration previously entered.

Example:

Call of ALARM H command three days after command with time adjustment.

```
LTU_10_FMM> ALARM H
~~~~~
Alarm History (day:hour:min)
~~~~~
-3:14:18  LOS-S alarm on
-3:14:18  remote alarm on
-3:14:20  LOS-S alarm off
-3:14:20  remote alarm off
~~~~~End of Alarm History~~~~~
LTU_10_FMM>
```

7.3.3.5 CLEAR Command

The CLEAR command erases all entries of the event log memory and the time declaration given by a previously entered ALARM H command with time adjustment. The internal system time is not resetted by this command.

A new event occuring after the CLEAR command will be displayed with the internal system time again.

```
LTU_10_FMM> CLEAR
18:46:10  alarm history cleared

...

LTU_10_FMM> ALARM H
~~~~~
Alarm History (day:hour:min)
~~~~~

~~~~~End of Alarm History~~~~~
LTU_10_FMM>
```

7.3.3.6 ACO Command

The ACO (Alarm Cut Off) command enables or disables the alarm relays. When ACO is 'on', all alarms are disabled and the alarm-relays are inactive. The local alarm LED signalizes a non-urgent alarm.

Unit	ACO	Monitor Display	Local LED (1)	Remote LED (2)	NTU LED
LTU Master	ON	Alarm cutoff activated	Orange	Green	Green
	OFF	Alarm cutoff deactivated	Green	Green	Green
NTU Slave	ON	Alarm cutoff activated	Green	Orange	Orange
	OFF	Alarm cutoff deactivated	Green	Green	Green

```
LTU_01_FMM> ACO ON
11:03:10 alarm cutoff activated
LTU_01_FMM> ACO OFF
11:11:70 alarm cutoff deactivated
```

7.3.3.7 LOOP1 Command

The LOOP1 command starts the local loopback:

```
LTU_01_FMM> LOOP1 ON
01:10:50 Loop 1 activated
LTU_01_FMM>
```

7.3.3.8 LOOP2 Command

The LOOP2 command starts the remote loopback:

```
LTU_01_FMM> LOOP2 ON
01:10:50 Loop 2 activated at remote station
LTU_01_FMM>
```

Note: The remote loopback is only possible from master side.

7.3.3.9 LOOPREGn Command

The LOOPREGn command starts the loopback in the nth regenerator:

```
LTU_01_FMM> LOOPREG1 ON
29:25:70 regenerator (1) loopback activated
LTU_01_FMM>
```

Note: This command is available on LTU-R only.

7.3.3.10 *STARTAL Command*

The STARTAL command starts the analog loopback:

```
LTU_01_FMM> STARTAL
01:04:00 analog loopback started
LTU_01_FMM>
```

Notes:

The system unit must be configured as master for analog loopback operation.

Detach the DSL line before starting the analog loopback. If the analog loopback is started while a remote station is attached to the DSL line, the remote station signal will interfere with the loopback signal, causing bit errors on the E1 side.

To return to normal operation, restart the system either by power up or RESET command or use the STOPAL command.

7.3.3.11 *STOPAL Command*

The STOPAL command stops the analog loopback

```
LTU_01_FMM> STOPAL
02:04:00 analog loopback stopped
LTU_01_FMM>
```

7.3.3.12 *TRACETIME Command*

The TRACETIME command allows the user to change the trace display repetition time (range: 1 .. 20 sec):

```
LTU_01_FMM> TRACETIME 3
04:10:30 trace time changed to 03 sec
LTU_01_FMM> TRACETIME 1
04:20:10 trace time changed to 01 sec
LTU_01_FMM>
```

7.3.3.13 *RESET Command*

By typing RESET, the system unit will be restarted.

```
LTU_01_FMM> RESET
05:06:10 system reset
```

Note:

On a Dual LTU both systems will be reset.

The RESET command will initiate a restart of the link, while the RESETCARD command will initiate a complete HW&SW reset. This reset must be confirmed within 30 sec.

7.3.3.14 RESETCARD Command

Upon execution of the RESETCARD command the screen comes as follows:

```
LTU_01_FMM> RESETCARD

*** Warning: this command will reset both SHDSL links of the Dual LTU
             enter reset command again to confirm (timeout after 30 sec)

LTU_01_FMM>

LTU_01_FMM> RESETCARD
46:35:30 reset command confirmed
46:35:30 system reset
```

7.3.4 Configuration Management CM

02:26:00 Configuration management activated
Type <M> to return to MAIN, or <H> for HELP information

Type <H> and the monitor lists all available commands in the configuration sub-menu:

```
LTU_01_CM> H
~~~~~
CONFIG          Display local configuration
G704 [ON,OFF]   Set framed mode / transparent mode
CRC4 [ON,OFF]   Set CRC4 mode on/off
EBIT [ON,OFF]   Set automatic E-Bit insertion on/off
AISGEN [ON,OFF] Set AIS generation on/off
AISDET [ON,OFF] Set AIS detection on/off
EXTCLK [ON,OFF] Set external clock mode on/off
MP              Display E1 time slot map
MP [0..3]       Set E1 time slot mapping mode
TS [0..3]       Select number of time slots
UIF type        Select user interface type
MASTER [ON,OFF] Set SHDSL master mode / slave mode
POWER [ON,OFF]  Set remote powering on/off
RESTART [ON,OFF] Set autorestart on/off
BACKOFF [ON,OFF] Set power backoff on/off
MODE [1,2]      Set SHDSL operating mode
DEFAULT [0..2]  Set default configuration
M(AIN)          Return to main menu
~~~~~
LTU_01_CM>
```

Notes:

The MASTER command is available on the LTU-L only (Jumper located on the PCB in position "RPWR OFF").

The POWER command is available on the LTU-R only (Jumper located on the PCB in position "RPWR ON").

The UIF type command selects only equipped user interfaces.

To display the current E1 time slot mapping mode, enter the MP command without parameter

7.3.4.1 CONFIG Command

The CONFIG command displays the configuration of the unit:

```
LTU_01_CM>CONFIG
~~~~~
Local Configuration                               Id : 2 Mbit/s G.703
~~~~~
2 Mbit/s,OFF]
  Framing           : ITU-T G.704
  CRC4              : On
  E-Bit Insertion  : On
  AIS Generation    : On
  AIS Detection     : On
  External Clock    : Disabled
  Data Rate         : 01 x 64 = 00064 kbit/s
  TS Mapping Mode   : 2
SHDSLRT [ON,OFF]
  Master/Slave     : Master
  Autorestart      : Enabled
  Power Backoff    : Disabled
  Payload Rate     : 00192 kbit/s
  Operating Mode   : 1 Pair
  Line Rate        : 00208 kbit/s
  Remote Powering  : On
  Regenerators     : --
TMN
  Address          : 01
  V.11 wires       : 02
~~~~~
LTU_01_CM>
```

- Notes:** After each configuration change, the new configuration is automatically displayed.
The Remote Powering and Regenerators configuration will be displayed for the LTU-R only.

7.3.4.2 Configuration Commands

E1 Interface

G704:	Set framed mode / transparent mode.
CRC4:	Set CRC4 mode on / off.
EBIT:	Set automatic E-Bit insertion on / off.
AISGEN:	Set AIS generation on / off.
AISDET:	Set AIS detection on / off.
EXTCLK:	Set external clock mode on / off.
MP	Set E1 mapping mode: 0 : TS0 not transmitted, TS16 only if frE1 > 16 1 : TS0 always transmitted, TS16 only if frE1 > 16 2 : TS0 not transmitted, TS16 always transmitted 3 : TS0 and TS16 always transmitted Multiservice only: ON: switch E1 Port on OFF: switch E1 Port off
UIF:	Set the user interface type to E1 or PRA.

PRA Interface

PRA:	Select the ISDN PRA functional entities of the modem: OFF: no PRA function (transparent transmission) NT1LT: both NT1 and LT LT: only LT NT1: only NT1
CRC4:	Set CRC4 processing option (Subscriber access option): 1 : digital link without CRC4 processing 2 : digital link with CRC4 processing 3 : option 3 is not available 4 : digital link with CRC4 monitoring This configuration selects the subscriber access option of the whole digital section (NT1 and LT) only if PRA Mode NT1 & LT is selected. If NT1 and LT functions run on different modems, the CRC4 settings of both modems determine the access option (see description of PRA configuration options).
CRC4SA6:	Set generation of CRC4 error notifications to the ET on / off (applies only to NT1).
MP	Display E1 time slot mapping

UIF: Set the user interface type to E1 or PRA.

DSL Interface

POWER: Set remote powering on / off.

MASTER: Set DSL master mode / slave mode.

BACKOFF: Set power back-off on / off.

RESTART: Set autorestart on / off.

BACKOFF: Set SHDSL Power Back-Off function on / off.

TS / LINERATE: Set line rate:

LINERATE n i a

n denotes the number of DSL time slots to be transmitted,
i = 1 denotes the Z-bits automatically used to increase the EOC
bandwidth of about 3.2 kbit/s by 8 kbit/s and
a = 1 denotes asymmetric PSD operation.

Default i = 1

Note: i = 0 or 1; $3 \leq n \leq 36$

Note: This command is no longer supported from SW-Version 1.4 and
follows. Use TS command instead.

MODE: Select DSL operating mode:

MODE 1: 1 pair operation

MODE 2: 2 pair operation

MODE 3: 3 pair operation

MODE 4: 4 pair operation

7.3.4.3 MP Command

The MP command sets and displays the E1 time slot mapping mode:

```

LTU_01_CM> MP 1
~~~~~
E1 Time Slot Map                                     (Mode: 1)
~~~~~
TS 0 0 0 0 0 0 0 0 0 0 1 1 1 1 1 1 1 1 1 1 2 2 2 2 2 2 2 2 2 3 3
Nr 0 1 2 3 4 5 6 7 8 9 0 1 2 3 4 5 6 7 8 9 0 1 2 3 4 5 6 7 8 9 0 1

Tx 1 1 1 1 1 1 1 1 1 1 1 1 1 1 1 1 1 1 1 1 1 1 1 1 1 1 1 1 1 1 1
Rx 1 1 1 1 1 1 1 1 1 1 1 1 1 1 1 1 1 1 1 1 1 1 1 1 1 1 1 1 1 1 1
~~~~~

```

Definitions:

Time slot marking:

Tx:

0 : time slot is not mapped to DSL

1 : time slot is mapped to DSL

N: time slot is mapped to DSL and contains nx64 data (nx64 - E1 applications)

- : E1 Port switched off (Multiservice only)

Rx:

0 : time slot is filled with all ones (except TS0)

1 : time slot is mapped from DSL

N: time slot is mapped from DSL and contains nx64 data (nx64 - E1 applications)

- -: DSL disconnected or

- -: E1 Port switched off (Multiservice only)

Notes:

To just display the current time slot mapping, enter MP command without parameter.

Tx mapping is given by the local configuration, Rx mapping by the mapping mode configured on the remote site. Basically, it is possible to use different mapping modes in each direction. However, if Tx and Rx mapping are not equal, a warning message will be displayed.

Examples:

1. Line rate 3, 1 Pair, Mapping Mode 0 (frE1 - frE1):

```

~~~~~
E1 Time Slot Map                                     (Mode: 0)
~~~~~
TS 0000000000001111111111222222222233
Nr 01234567890123456789012345678901

Tx 0111000000000000000000000000000000
Rx 0111000000000000000000000000000000
~~~~~

```

2. Line rate 3, 1 Pair, Mapping Mode 1 (frE1 - frE1):

```

-----
E1 Time Slot Map                (Mode: 1)
-----
TS 00000000000111111111222222222233
Nr 01234567890123456789012345678901

Tx 11100000000000000000000000000000
Rx 11100000000000000000000000000000
-----

```

3. Line rate 3, 1 Pair, Mapping Mode 2 (frE1 - frE1):

```

-----
E1 Time Slot Map                (Mode: 2)
-----
TS 00000000000111111111222222222233
Nr 01234567890123456789012345678901

Tx 01100000000000000100000000000000
Rx 01100000000000000100000000000000
-----

```

4. Line rate 3, 1 Pair, Mapping Mode 3 (frE1 - frE1):

```

-----
E1 Time Slot Map                (Mode: 3)
-----
TS 00000000000111111111222222222233
Nr 01234567890123456789012345678901

Tx 11000000000000000100000000000000
Rx 11000000000000000100000000000000
-----

```

5. Line rate 3, 1 Pair, Mapping Mode x (frE1 – nx64):

```

-----
E1 Time Slot Map                (Mode: x)
-----
TS 00000000000111111111222222222233
Nr 01234567890123456789012345678901

Tx 0NNN0000000000000000000000000000
Rx 0NNN0000000000000000000000000000
-----

```

7.3.4.4 TS Command

The TS command sets the line rate by means of timeslots.

It takes into account the number of pairs used at the time, and also the mapping mode present.

SYNTAX: TS n n=1...31

```
LTU_01_CM> TS 12
~~~~~
Local Configuration                                     Id : 2 Mbit/s G.703
~~~~~
2 Mbit/s
  Framing           : ITU-T G.704
  CRC4              : On
  E-Bit Insertion  : On
  AIS Generation    : On
  AIS Detection     : On
  External Clock    : Disabled
  Data Rate         : 12 x 64 = 00768 kbit/s
  TS Mapping Mode   : 1
SHDSL
  Master/Slave     : Master
  Autorestart      : Enabled
  Power Backoff    : Disabled
  Payload Rate     : 00896 kbit/s
  Operating Mode   : 2 Pair
  Line Rate        : 00456 kbit/s
  Remote Powering  : On
  Regenerators     : --
TMN
  Address          : 01
  V.11 wires      : 02
~~~~~
LTU_01_CM>
```

Notes: This command is activated with selected firmware versions only.

7.3.4.5 MODE Command

The MODE command sets the 1p, 2p, 3p and 4p operation between LTU and NTU.

MODE 1: 1p operation enabled

MODE 2: 2p operation enabled

MODE 3: 3p operation enabled

MODE 4: 4p operation enabled

In 3p and 4p mode the Pair Identification has to be taken into account

<i>Operation</i>	<i>Specification</i>	<i>Rate</i>
3p operation	Max data rate of E1 user interface	32 x 64kbit/s
	Max data rate of nx64 user interface	96 x 64kbit/s
	Max user data rate per pair	36x64kbit/s
	Pair Identification and Cabling	No restrictions
4p operation	Max data rate of E1 user interface	32 x 64kbit/s
	Max data rate of nx64 user interface	96 x 64kbit/s
	Max user data rate per pair	Pair A&B: 30 x 64 kbit/s Pair C&D: 18 x 64 kbit/s
	Pair Identification and Cabling	Free pair cabling for data rates up to 72 x 64 kbit/s Pair crossing A↔B, C↔D allowed for higher data rates, Pair crossing AB↔CD prohibited, PID alarm will show up

Table 7-2: 3p and 4p limitations

7.3.4.6 DEFAULT Command

The DEFAULT command sets a default configuration. Three default settings are available:

```

LTU_10_CM> DEFAULT 0
Local Configuration                                     Id : 2 Mbit/s G.703
~~~~~
2 Mbit/s
  Framing           : Transparent
  CRC4              : --
  E-Bit Insertion  : --
  AIS Generation    : On
  AIS Detection     : On
  External Clock    : --
  Data Rate        : 32 x 64 = 02048 kbit/s
SHDSL
  Master/Slave     : Master
  Autorestart      : Enabled
  Power Backoff    : Disabled
  Payload Rate     : 02048 kbit/s
  Operating Mode   : 1 Pair
  Line Rate        : 02056 kbit/s
  Remote Powering  : Off
  Regenerators     : --
TMN
  Address          : 10
  V.11 wires      : 02
~~~~~
LTU_10_CM>

LTU_10_CM> DEFAULT 1
Local Configuration                                     Id : 2 Mbit/s G.703
~~~~~
2 Mbit/s
  Framing           : ITU-T G.704
  CRC4              : On
  E-Bit Insertion  : On
  AIS Generation    : On
  AIS Detection     : On
  External Clock    : Disabled
  Data Rate        : 31 x 64 = 01984 kbit/s
SHDSL
  Master/Slave     : Master
  Autorestart      : Enabled
  Power Backoff    : Disabled
  Payload Rate     : 02048 kbit/s
  Operating Mode   : 1 Pair
  Line Rate        : 02056 kbit/s
  Remote Powering  : Off
  Regenerators     : --
TMN
  Address          : 10
  V.11 wires      : 02
~~~~~
LTU_10_CM>

```

```
LTU_10_CM> DEFAULT 2
~~~~~
Local Configuration                               Id : 2 Mbit/s G.703
~~~~~
2 Mbit/s
  Framing           : Transparent
  CRC4              : --
  E-Bit Insertion  : --
  AIS Generation    : On
  AIS Detection     : Off
  External Clock    : --
  Data Rate        : 32 x 64 = 02048 kbit/s
SHDSL
  Master/Slave     : Master
  Autorestart      : Enabled
  Power Backoff    : Disabled
  Payload Rate     : 02048 kbit/s
  Operating Mode   : 1 Pair
  Line Rate        : 02056 kbit/s
  Remote Powering  : Off
  Regenerators     : --
TMN
  Address          : 10
  V.11 wires      : 02
~~~~~
LTU_10_CM>
```

The factory setting can be loaded using the "DEFAULT 2" command. All DSL LTUs and NTUs are delivered with this configuration (LTUs as master, NTUs as slave).

Note: The Master/Slave and Remote Powering settings are not affected by the DEFAULT command.

7.3.5 Accounting Management AM

Accounting management is not supported.

7.3.6 Security and Remote Management SM

04:35:90 Security and remote management activated
type <M> to return to MAIN, or <H> for HELP information

Type <H> and the monitor lists all available commands in the security sub-menu:

```
LTU_08_SM> H
~~~~~
CONNECT adr          Connect remote terminal (adr=[2..10])
DISCONNECT          Disconnect remote terminal(s)
RHM                 Read HM-Code
RCHM                Read CHM-Code
M(AIN)              Return to main menu
~~~~~
```

7.3.6.1 CONNECT and DISCONNECT Command

The CONNECT command sets a connection to the remote unit for configuration purposes (unit addresses as per TS 101 524, if no address is entered, then default address is 2 = NTU).

The DISCONNECT command breaks the connection to the remote unit. If no remote terminal is currently connected, the DISCONNECT command will list all remote units currently available. Instead of typing DISCONNECT, the ESC key can be used alternatively to return to the local terminal in a more convenient way.

Note: The CONNECT and DISCONNECT commands are also available from all other sub-menus, but not displayed in the respective HELP screen.

7.3.6.2 RHM Command

The RHM command reads out the HM code from the EEPROM of the connected device and displays it on the terminal.

The HM code includes the serial number of the device, as well as information about manufacturer and guarantee.

7.3.6.3 RCHM Command

The RCHM command reads out the CHM code of the connected device.

The CHM code includes the hardware type identifier, revision information about hardware and software as well as the default settings for delivery.

7.4 Monitor Commands for the nx64 kbit/s Interface

This section deals only with nx64 kbit/s specific monitor commands.

7.4.1 Fault and Maintenance Management FMM

7.4.1.1 ALARM Command

```
NTU_FMM> ALARM
~~~~~
Local Alarm Status
~~~~~
DTR-S:off   LOOP1:off   ACO:off
LOC-S:off   LOOP2:off   ALB:off
LOSW-A:off  BER-A:off   SEG-A:off  BERT:off
~~~~~
NTU_FMM>
```

These alarms are related to the nx64 kbit/s interface:

DTR-S: Status of DTR (Data Terminal Ready) Handshake Signal in V.35/V.36 mode. For X.21 mode, the Control-signal (C) is represented by the DTR-alarm.

DTR Signal is detected as 'ON' (Status: off)

DTR Signal is detected as 'OFF' (Status: on)

LOC-S: Loss Of Clock (When Local Clock mode is selected). LOC is also active when the incoming clock bit rate is not equal to the programmed bit rate (n).

Clock master present with correct bit rate (Status: off)

Clock master not present and/or bit rate mismatch (Status: on)

When both an nx64 kbit/s and an E1 interface are equipped, the alarm display shows first the E1/PRA alarms and then the nx64 kbit/s alarms.

7.4.2 Configuration Management CM

User Interface in V.35 or V.36 mode

```

NTU_CM> H
~~~~~
CONFIG          Display local configuration
BITRATE [0..72] Set bit rate of nx64 Port
CLOCKMODE [0,2,3] Select clock source:
                  0=nx64 Port, 2=internal, 3=remote
CLOCKDIR [0,1]  Set clock direction of nx64 Port:
                  0=codir, 1=contradir
V54LOOPS [ON,OFF] Set V.54 loop control on/off
HANDSHAKE [ON,OFF] Set RTS/CTS (C/I) handshake on/off
UIF type        Select user interface type
MASTER [ON,OFF] Set SHDSL master mode / slave mode
RESTART [ON,OFF] Set autorestart on/off
BACKOFF [ON,OFF] Set power backoff on/off
DEFAULT [0..2]  Set default configuration
M(AIN)          Return to main menu
~~~~~
NTU_CM>

```

User interface in X.21 mode

```

NTU_CM> H
~~~~~
CONFIG          Display local configuration
BITRATE [0..72] Set bit rate of nx64 Port
CLOCKMODE [0,2,3] Select clock source:
                  0=nx64 Port, 2=internal, 3=remote
CLOCKPOL [0,1]  Set clock polarity of nx64 Port:
                  0=normal, 1=inverted
BYTETIMING [ON,OFF] Set byte timing on/off
HANDSHAKE [ON,OFF] Set RTS/CTS (C/I) handshake on/off
UIF type        Select user interface type
MASTER [ON,OFF] Set SHDSL master mode / slave mode
RESTART [ON,OFF] Set autorestart on/off
BACKOFF [ON,OFF] Set power backoff on/off
DEFAULT [0..2]  Set default configuration
M(AIN)          Return to main menu
~~~~~
NTU_CM>

```

When both an nx64 kbit/s and an E1 interface are equipped, also E1 or PRA specific configuration commands will be listed in the menu.

7.4.2.1 CONFIG Command

The CONFIG command displays the configuration of the NTU unit (e.g. V.35):

```

NTU_CM> CONFIG
~~~~~
Local Configuration                               Id : nx64 kbit/s V.35
~~~~~
V.35
  Bit Rate      : 32 x 64 = 02048 kbit/s
  Clock Mode    : Remote
  Clock Direction : Codirectional
  V.54 Loops    : Disabled
  Handshake     : Disabled
SHDSL
  Master/Slave  : Slave
  Autorestart   : Enabled
  Power Backoff : Disabled
  Payload Rate  : 02048 kbit/s
  Operating Mode : 1 Pair
  Line Rate     : 02056 kbit/s
~~~~~
NTU_CM>

```

When both an nx64 kbit/s and an E1 interface are equipped, the configuration display shows first the E1/PRA configuration and then the nx64 kbit/s configuration:

```

~~~~~
Local Configuration                               Id : Multiservice
~~~~~
2 Mbit/s
  Framing      : ITU-T G.704
  CRC4         : Off
  E-Bit Insertion : --
  AIS Generation : On
  AIS Detection : Off
  Data Rate    : 11 x 64 = 00704 kbit/s
X.21
  Bit Rate     : 20 x 64 = 01280 kbit/s
  Clock Mode   : Remote
  Clock Polarity : Normal
  Byte Timing  : Off
  Handshake    : Disabled
SHDSL
  Master/Slave  : Slave
  Autorestart   : Enabled
  Power Backoff : Disabled
  Payload Rate  : 02048 kbit/s
  Operating Mode : 1 Pair
  Line Rate     : 02056 kbit/s
~~~~~

```

Warning: If the nx64 kbit/s interface has to be configured under remote power conditions, be sure not to configure it from E1 interface at the remote power limit. Due to the higher power consumption of the nx64 kbit/s interface at the NTU side the current limiter at the LTU will possibly operate thus switching off remote power feeding. Subsequent startup will not be successful. The system remains unconfigurable till the NTU is reconfigured locally at the NTU site!

7.4.2.2 *BITRATE Command*

Set bit rate of nx64 Port : n = [0..36 for Dual LTU / 0..72 for NTU]

To switch off the nx64 Port, set bit rate to 0.

7.4.2.3 *CLOCKMODE Command*

Select clock source: 0=nx64 Port, 1=E1 Port 2, 2=Internal, 3=Remote.

7.4.2.4 *CLOCKDIR Command*

Select clock direction: 0=codirectional, 1=contradirectional.

This command is only available in V.35 and V.36 modes.

7.4.2.5 *V54LOOPS Command*

Select whether it is possible to switch loop 1 and 2 using the control circuits 140 (RL) and 141 (LL).

This command is only available in V.35 and V.36 modes.

7.4.2.6 *CLOCK POLARITY Command*

The CLOCK POL commands selects the sampling instant for the incoming data stream on circuit T of the X.21 user interface.

In default configuration "normal" circuit T is sampled on rising edge of clock S.

The data transitions on T and R shall occur at the OFF to ON transition of S (according X.24 standard). The ON to OFF transition of circuit S nominally indicates the centre of each signal element on circuit R in this case.

When Clock Polarity is set to "inverted", circuit T is sampled with the falling slope of S. The incoming data at X.21 circuit T will be sampled at the OFF to ON transition of S.

This command is only available in X.21 mode.

7.4.2.7 *BYTETIMING Command*

Select if circuit B for byte timing is used in X.21 mode. Note that to use the byte timing you need the appropriate cable and cannot use the co-directional transmit clock.

This command is only available in X.21 mode.

7.4.2.8 *HANDSHAKE Command*

Set RTS/CTS (C/I) handshake mode.

A.) User interface type V.35/V.36

HANDSHAKE ON:

Circuit 107 (DSR) and 109 (RLSD) are set into status ON when a SHDSL link is established.
Circuit 106 (CTS) is set to status ON only when link is established
AND circuit 105 (RTS) is in ON state.

HANDSHAKE OFF:

Circuit 106 (CTS), 107 (DSR) and 109 (RLSD) are set into status ON when a SHDSL link is established.

Status of circuit 108 (DTR) is detected and displayed by DTR-S alarm in both cases

B.) User interface type X.21

HANDSHAKE ON:

Circuit I is set to status ON only when circuit C is in ON state.
Interruption of SHDSL link has no influence on status of I.

HANDSHAKE OFF:

Circuit I is set permanently to status ON independent of circuit C state.

7.4.2.9 UIF Command

Select the interface type: V35 = V.35, V36 = V.36, X21 = X.21.

When both an nx64 kbit/s and an E1 interface are equipped, also the values E1 and PRA are possible to switch between E1 and PRA mode.

7.4.2.10 DEFAULT Command

The DEFAULT command sets a default configuration.

When both an nx64 kbit/s and an E1 interface are equipped, a default configuration is set for both interfaces.

Three default settings are available for the nx64 kbit/s interface:

```
NTU_CM> DEFAULT 0
~~~~~
Local Configuration                               Id : nx64 kbit/s V.35
~~~~~
V.35
  Bit Rate           : 32 x 64 = 02048 kbit/s
  Clock Mode         : Remote
  Clock Direction    : Codirectional
  V.54 Loops         : Disabled
  Handshake          : Disabled
SHDSL
  Master/Slave       : Slave
  Autorestart        : Enabled
  Power Backoff      : Disabled
  Payload Rate       : 02048 kbit/s
  Operating Mode     : 1 Pair
  Line Rate          : 02056 kbit/s
~~~~~
NTU_CM>
```

```
NTU_CM> DEFAULT 1
~~~~~
Local Configuration                               Id : nx64 kbit/s V.35
~~~~~
V.35
  Bit Rate      : 32 x 64 = 02048 kbit/s
  Clock Mode    : Internal
  Clock Direction : Codirectional
  V.54 Loops    : Disabled
  Handshake     : Disabled
SHDSL
  Master/Slave  : Slave
  Autorestart   : Enabled
  Power Backoff : Disabled
  Payload Rate  : 02048 kbit/s
  Operating Mode : 1 Pair
  Line Rate     : 02056 kbit/s
~~~~~
NTU_CM>
```

```
NTU_CM> DEFAULT 2
~~~~~
Local Configuration                               Id : nx64 kbit/s V.35
~~~~~
V.35
  Bit Rate      : 32 x 64 = 02048 kbit/s
  Clock Mode    : Remote
  Clock Direction : Codirectional
  V.54 Loops    : Disabled
  Handshake     : Disabled
SHDSL
  Master/Slave  : Slave
  Autorestart   : Enabled
  Power Backoff : Disabled
  Payload Rate  : 02048 kbit/s
  Operating Mode : 1 Pair
  Line Rate     : 02056 kbit/s
~~~~~
NTU_CM>
```

7.5 Monitor Commands for LTU Minirack TMN Interface

For Minirack versions of the LTU, the address number of the DSL interface can be set manually by monitor commands in the Configuration Management (CM) menu.

After power-up of a Minirack LTU always the local monitor main menu appears with the first DSL system activated (behaviour like a NTU).

Address numbers in range 1-127 can be set independently to the different DSL systems of a LTU.

The alternatives of running the TMN communication on a 2- or 4-wire bus can be selected in the CM menu as well. The list below shows the available commands in the Configuration Management menu of a Minirack LTU.

RESET command, DEFAULT command or power down has no influence on settings made for the TMN interface.

```
LTU_01_CM> H
~~~~~
CONFIG          Display local configuration
G704 [ON,OFF]   Set framed mode / transparent mode
CRC4 [ON,OFF]   Set CRC4 mode on/off
EBIT [ON,OFF]   Set automatic E-Bit insertion on/off
AISGEN [ON,OFF] Set AIS generation on/off
AISDET [ON,OFF] Set AIS detection on/off
EXTCLK [ON,OFF] Set external clock mode on/off
MP [0..3]       Set E1 time slot mapping mode
POWER [ON,OFF]  Set remote powering on/off
RESTART [ON,OFF] Set autorestart on/off
BACKOFF [ON,OFF] Set power backoff on/off
LINERATE n i a  Select line rate (n=[3..36] i=[0,1] a=[0,1])
MODE [1,2]      Set SHDSL operating mode
ADDRESS [1..127] Set TMN address
V11WIRES [2,4]  Set number of V.11 wires
DEFAULT [0..2]  Set default configuration
M(AIN)         Return to main menu
~~~~~
LTU_01_CM>
```

7.5.1 ADDRESS Command

The ADDRESS command allows the user to assign an address number in the range between 1–127 to the current DSL interface of a Minirack LTU.

```

LTU_01_CM> ADDRESS 04
~~~~~
Local Configuration                               Id : 2 Mbit/s G.703
~~~~~
2 Mbit/s
  Framing           : ITU-T G.704
  CRC4              : On
  E-Bit Insertion  : On
  AIS Generation    : On
  AIS Detection     : On
  External Clock    : Disabled
  Data Rate        : 31 x 64 = 01984 kbit/s
SHDSL
  Master/Slave     : Master
  Autorestart      : Enabled
  Power Backoff    : Disabled
  Payload Rate     : 02048 kbit/s
  Operating Mode   : 1 Pair
  Line Rate        : 02056 kbit/s
  Remote Powering  : On
  Regenerators     : --
TMN
  Address          : 04
  V.11 wires      : 04
~~~~~
LTU_01_CM>

```

Note: **For a Dual LTU Minirack it is possible to assign a higher interface address number to DSL system A than to DSL system B.**

For Plug-in LTUs the lowest interface number is always assigned to DSL system A and the pins with appropriate designation on the DSL connector of type RJ-45.

Note: **Carefully note already used interface address numbers. No automatic protection against multiple LTUs assigned to the same interface address number can be applied in a set-up with several Minirack LTUs.**

Two interfaces with same address number on the TMN bus will cause malfunction and the units will not be accessible by the TMN application SW.

Limitation: **Both DSL systems of a Dual LTU can be addressed freely. But possible addresses are limited to the address ranges 01 - 12 and 33 – 44 by the Simple Network Management Protocol (SNMP) used for communication with the Management Centre.**

7.5.2 V.11 WIRES Command

The V11WIRES command allows to switch between 2- or 4-wire communication on the TMN interface (EIA-485 bus).

```
LTU_01_CM> V11WIRES 2
~~~~~
Local Configuration                               Id : 2 Mbit/s G.703
~~~~~
2 Mbit/s
  Framing           : ITU-T G.704
  CRC4              : On
  E-Bit Insertion  : On
  AIS Generation    : On
  AIS Detection     : On
  External Clock    : Disabled
  Data Rate         : 31 x 64 = 01984 kbit/s
SHDSL
  Master/Slave     : Master
  Autorestart      : Enabled
  Power Backoff    : Disabled
  Payload Rate     : 02048 kbit/s
  Operating Mode   : 1 Pair
  Line Rate        : 02056 kbit/s
  Remote Powering  : On
  Regenerators     : --
TMN
  Address          : 04
  V.11 wires       : 02
~~~~~
LTU_01_CM>
```

Note: **4-wire communication is recommended for Minirack configurations.**

Note: **4-wire communication requires a crossing of Rx and TX signals between CMU and LTU. 2-wire communication uses only Rx A and Rx B wires without any crossing.**

8 Point-to-Multipoint Operation

This chapter describes the point to multipoint operation.

8.1 Features

- In point-to-multipoint operation the time slots of the E1 frame may be sent to different NTUs. In the Watson 5 point-to-multipoint implementation the time slots of the two E1 interfaces may be assigned to four DSL loops.
- It is configurable which time slots on the DSL loops are used to carry the data from the E1 interface.
- To distribute the time slots from one E1 interface to more than four DSL loops, multipoint LTUs can be cascaded.

Figure 8-1 shows some examples of multipoint configurations, which are obtained by configuring explicitly point-to-point links. (Switching-off multipoint mode yields configuration a) = pure dual LTU operation.) In addition, LTUs can be cascaded e) to increase the number of links.

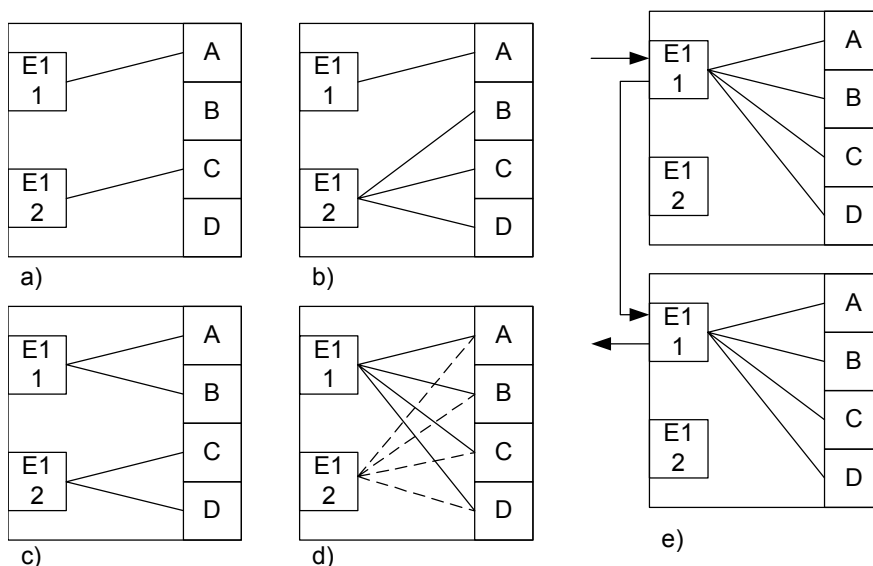

Figure 8-1: Examples of Multipoint Configuration

A multipoint LTU has two E1 interfaces (numbered 1 and 2) and four DSL interfaces (denoted A, B, C and D). The LTU behaves like four single LTUs in a rack, i.e. it is addressable by four addresses representing four systems. The address of the 1st system is given by the slot position in the rack (like for a single LTU). The address of the 2nd system is the 1st system's address + 12, the 3rd and 4th addresses are calculated by adding 24 and 36. The two E1 interfaces are assigned to the 1st and 3rd system; the 2nd and 4th system have only a DSL interface. When the multipoint mode is switched off, the 1st and the 3rd system work just like two E1 LTUs (the 1st system uses E1 interface 1 and DSL loop A; the 3rd system uses E1 interface 2 and DSL loop C); the 2nd and 4th system are not used in this case. In multipoint mode, the time slots from the E1 interfaces can be distributed freely to the available DSL loops, i.e. there is no more a fixed linkage between E1 and DSL interfaces. The assignment of the interfaces to systems is only relevant when configuring the interfaces.

8.2 Configuration

The configuration of a point-to-multipoint system includes three steps:

- configure the E1 and DSL interfaces,
- assign the time slots from the E1 interfaces to the DSL loops,
- for each DSL loop, select the time slots, which are filled with the data from the E1 interfaces.

The following sections describe these three steps using the monitor's configuration commands.

8.2.1 E1 and DSL Interface Configuration

For point-to-multipoint operation, the 32 time slots of an E1 frame are sent to different remote modems. To structure the signal at the E1 interface into different time slots, the bit stream has to be divided into frames, thus the E1 interface has to work in framed mode. When CRC4 multiframes are used, CRC4- and E-Bit insertion has to be switched on. The E1 interfaces at the remote stations should work in the same mode.

The DSL interfaces used for point-to-multipoint operation must be in DSL master mode; the DSL interfaces at the remote stations are slaves. The line rates have to be chosen to allow maximal range first. Hence the number of time slots that can be carried is limited by: line rate - 16kbit/s (a line rate of $n \cdot 64\text{kbit/s} + 16\text{kbit/s}$ can carry at most n time slots). DSL loops A and B must have the same line rate (can be configured in the 1st system), and also DSL loops C and D must have the same line rate (can be configured in the 3rd system). So if you have two remote modems which are connected by long loops and two other remote stations which are not that far away, use loops A and B (or C and D) for the first two modems and the remaining two loops for the other ones and select two appropriate line rates.

8.2.2 Assignment of E1 Time Slots to the DSL Loops

When the E1 and DSL interfaces have been set up, the time slots can be 'switched' from the E1 to the DSL interfaces. Each time slot of an E1 interface must be mapped to a DSL loop.

Example: The command

```
LTU_01_CM> MP 1 AAAAAAAAAAAAAAAAABBBBBBBBBBBBBBBB
~~~~~
Multipoint Configuration
~~~~~
TS 0 0 0 0 0 0 0 0 0 0 1 1 1 1 1 1 1 1 1 2 2 2 2 2 2 2 2 2 3 3
Nr 0 1 2 3 4 5 6 7 8 9 0 1 2 3 4 5 6 7 8 9 0 1 2 3 4 5 6 7 8 9 0 1

1  a a a a a a a a a a a a a a a b b b b b b b b b b b b b b
2  - - - - - - - - - - - - - - - - - - - - - - - - - - - - -
A  - - - - - - - - - - - - - - - - - - - - - - - - - - - - -
B  - - - - - - - - - - - - - - - - - - - - - - - - - - - - -
C  - - - - - - - - - - - - - - - - - - - - - - - - - - - - -
D  - - - - - - - - - - - - - - - - - - - - - - - - - - - - -
~~~~~
LTU_01_CM>
```

assigns time slots 0 to 15 (from E1 interface 1) to loop A and time slots 16 to 31 to loop B. The first parameter of the MP command is the interface to be configured, '1' selects E1 interface 1, '2' selects the 2nd E1 interface. The second parameter is a string of up to 32 characters. The first character determines the target for the first time slot (TS0), the subsequent characters are assigned to subsequent time slots. The current multipoint configuration will be displayed. The first two lines number the time slots of the interfaces from 00 to 31. The lines named '1' and '2' contain the configuration of E1 interfaces 1 and 2, the lines 'A', 'B', 'C' and 'D' display time slots used on the DSL loops A to D.

The characters used for the E1 interface are:

- A...D: assign time slot to DSL loop,
- 0: time slot is not used (for unused time slots, all ones are received),
- L: time slot is looped back

If the second parameter contains less than 32 characters, the remaining time slots are unused. To switch off all time slots of the 1st E1 interface, "MP 1 OFF" (or "MP 1 0") can be used. The use of the character 'L' to loop back time slots is explained in the section "Cascading Multipoint LTUs".

8.2.3 DSL Time Slot Selection

Once the E1 time slots are assigned to the different DSL loops, it has to be selected which DSL time slots carry the E1 data. The DSL time slots are numbered from 0 to 31. The numbers define the E1 time slot which is carried in that DSL time slot when using standard time slot mapping according to ETSI TS 300 311, i.e. if you have an E1 modem at the remote end, DSL time slot **n** will be mapped to E1 time slot **n**.

We continue with our configuration example. Time slots 0 to 15 of E1 interface 1 are assigned to DSL loop A, time slots 16 to 31 to loop B. If we assume a line rate of 2064kbit/s for loops A and B, we can carry 32 time slots on both loops. However, we only have 16 time slots assigned to each DSL loop, thus we have to select which of the available 32 time slots will 'carry' the 16 E1 time slots. To use time slots 0 to 15 on loop A and time slots 1 to 16 on loop B, use these commands.

```

LTU_01_CM> MP A 11111111111111110000000000000000
~~~~~
Multipoint Configuration
~~~~~
TS 0 0 0 0 0 0 0 0 0 0 1 1 1 1 1 1 1 1 1 1 2 2 2 2 2 2 2 2 2 2 3 3
Nr 0 1 2 3 4 5 6 7 8 9 0 1 2 3 4 5 6 7 8 9 0 1 2 3 4 5 6 7 8 9 0 1

1  A A A A A A A A A A A A A A A b b b b b b b b b b b b b b b b b
2  - - - - - - - - - - - - - - - - - - - - - - - - - - - - - - - -

A  1 1 1 1 1 1 1 1 1 1 1 1 1 1 1 1 - - - - - - - - - - - - - - -
B  - - - - - - - - - - - - - - - - - - - - - - - - - - - - - - - -
C  - - - - - - - - - - - - - - - - - - - - - - - - - - - - - - - -
D  - - - - - - - - - - - - - - - - - - - - - - - - - - - - - - - -

~~~~~
LTU_01_CM> MP B 01111111111111111100000000000000
~~~~~
Multipoint Configuration
~~~~~
TS 0 0 0 0 0 0 0 0 0 0 1 1 1 1 1 1 1 1 1 1 2 2 2 2 2 2 2 2 2 2 3 3
Nr 0 1 2 3 4 5 6 7 8 9 0 1 2 3 4 5 6 7 8 9 0 1 2 3 4 5 6 7 8 9 0 1

1  A A A A A A A A A A A A A A A B B B B B B B B B B B B B B B B B
2  - - - - - - - - - - - - - - - - - - - - - - - - - - - - - - - -

A  1 1 1 1 1 1 1 1 1 1 1 1 1 1 1 1 - - - - - - - - - - - - - - -
B  - 1 1 1 1 1 1 1 1 1 1 1 1 1 1 1 1 - - - - - - - - - - - - - - -
C  - - - - - - - - - - - - - - - - - - - - - - - - - - - - - - - -
D  - - - - - - - - - - - - - - - - - - - - - - - - - - - - - - - -

~~~~~
LTU_01_CM>

```

The 'MP' command is used with the first parameter 'A' for loop A and 'B' for loop B. The second parameter contains 32 characters, which are assigned to the 32 time slots on the DSL loops. The string can contain the numbers 0 to 2:

- 0: time slot is not used (send/receive all ones),
- 1 or 2: the next time slot from E1 interface 1 or 2 is sent and received in this DSL time slot.

The order of the time slots on the DSL loop is the same as in the E1 frame. In our example time slot 0 from E1 interface 1 is the first time slot assigned to loop A. It will be transmitted on the first time slot in DSL loop A whose character is '1'. The second time slot assigned to loop A (E1 time slot 1) will be assigned to the second time slot in DSL loop A whose character is '1', and so on.

If the second parameter has less than 32 characters, the remaining time slots are unused, so you can use "MP B 0111111111111111" instead of "MP B 01111111111111111100000000000000". To switch off all time slots, "OFF" can be used as the second parameter.

Note: TSO is used for E1 framing FAS/NFAS and will be overwritten at the remote end. Thus TSO on the DSL loops can only be used for transmission of TSO from an E1 interface. In our example, TSO of DSL loop A is used for TSO from E1 interface 1, whereas TSO of DSL loop B is not used.

8.2.4 MP Command

The previous configuration example illustrated several uses of the MP command. This section describes more aspects of the MP command and the multipoint configuration.

The MP command has two parameters:

MP cmd map

<i>cmd</i>	<i>map</i>	<i>Description</i>
-	-	Show current multipoint configuration
OFF	-	Switch off multipoint mode, the LTU can then be used as a normal dual LTU with the 1 st and the 3 rd system.
ON	-	Switch on multipoint mode, the multipoint configuration used before the last "MP OFF" will be restored.
1, 2	0ABCDL	Set mapping of E1 time slots from E1 interface <i>cmd</i> to DSL loops: 0: TS unused (filled with 11111111) A: TS mapped to DSL loop A B: TS mapped to DSL loop B C: TS mapped to DSL loop C D: TS mapped to DSL loop D L: TS looped back
A,B,C,D	012	Select which DSL time slots are used on loop <i>cmd</i> . 0: TS unused (filled with 11111111) 1, 2: TS filled with TS from E1 interface

After every configuration change, the current multipoint configuration is displayed:

```

~~~~~
Multipoint Configuration
~~~~~
TS 0 0 0 0 0 0 0 0 0 0 1 1 1 1 1 1 1 1 1 1 2 2 2 2 2 2 2 2 2 3 3
Nr 0 1 2 3 4 5 6 7 8 9 0 1 2 3 4 5 6 7 8 9 0 1 2 3 4 5 6 7 8 9 0 1

1  - A A A A A A A A A A B B B B B B B B C C C C C D D D D A
2  - - - - - - - - - - - - - - - - - - - - - - - - - - - -

A  - 1 1 1 - 1 1 1 1 1 1 1 1 - - - - - - - - - - - - - - - -
B  - 1 1 1 1 1 1 1 1 1 1 - - - - - - - - - - - - - - - -
C  - - - - - - - - 1 1 1 1 1 - - - - - - - - - - - - - - -
D  - 1 - 1 - 1 - 1 - - - - - - - - - - - - - - - - - - - -
~~~~~

```

The columns show the time slots (0...31), the rows the interfaces (E1 interfaces 1 and 2, DSL interfaces A, B, C and D). In the configuration above, the following mapping is displayed:

E1 interface 1 TS0	→	unused,
E1 interface 1 TS1 ... 10, 31	→	DSL interface A TS1 ... 3, 5 ... 12,
E1 interface 1 TS11 ... 20	→	DSL interface B TS1 ... 10,
E1 interface 1 TS21 ... 26	→	DSL interface C TS8 ... 13,
E1 interface 1 TS27 ... 30	→	DSL interface D TS1, 3, 5, 7,
E1 interface 2 TS0 ... 31	→	unused.

First the E1 time slot mapping has to be configured. The loop characters in the "Multipoint Configuration" display will be shown in lower case ('a' ... 'd'), which means that a time slot has been assigned to a loop, but its position on that loop has not yet been defined.

Thereafter, the time slots which are used on the DSL loops have to be selected. Time slots which are selected on the loop will be displayed in upper case ('A' ... 'D') in the E1 time slot mapping. If you select more time slots than are actually mapped to the loop by the E1 mapping, superfluous time slots will not be enabled. Also time slots which are outside of the range used by the line rate configured will not be enabled.

The following restrictions apply for the multipoint configuration:

- You cannot map from both E1 interfaces to the same DSL loop.
- You must map from the same E1 interface to DSL loops C and D. Loops A and B can use time slots from different E1 interfaces.
- When one E1 interface uses only loop A, the other E1 interface cannot use only loop B. It should use either loop C or loop D in that case.
- Loops C and D together can use 47 time slots. This will not restrict the number of time slots to be mapped to these loops since they have to use the same E1 interface, and thus only can have 32 time slots. However, some fancy mappings are not possible, because the two loops share their 47 bytes using two overlapping windows of 32 bytes and the overlapping area can only be used by one of the two loops (the memory allocation of the two windows is done in chunks of 8 bytes). This restriction has only an effect if you use for both loops C and D time slots at the begin (e.g. TS1) and at the end (e.g. TS31) of the frame.
- The number of time slots looped back has to be a power of 2, i.e. 2, 4, 8 or 16 (see section "Cascading Multipoint LTUs").

8.2.5 Cascading Multipoint LTUs

If only a small number of time slots has to be sent to every remote station, four DSL loops per E1 interface are not enough to use all 32 time slots. In such cases, multiple LTUs can be cascaded. The principle used for it is as follows:

The time slots that are assigned to the four DSL loops of the LTU are mapped as in the normal case.

The time slots that are assigned to DSL loops of other LTUs are looped back.

The E1 transmit signal is connected to the E1 input of the 1st LTU. The E1 output of the 1st LTU will contain the received time slots assigned to the DSL loops of the 1st LTU plus the looped back time slots which are unchanged. This E1 output is connected to the E1 input of the 2nd LTU. The 2nd LTU will send time slots to its four remote stations that have been looped back in the 1st LTU. It will loop back those time slots, which have been used by the 1st LTU, and also all other time slots, which are used by other LTUs. The E1 output of the 2nd LTU contains the time slots received from remote stations connected to the 2nd LTU and the looped back time slots (these include the time slots which have been received by the 1st LTU and have not been changed by the 2nd LTU). This E1 output goes to the E1 input of the next LTU and so on. The E1 output of the last LTU is the common E1 receiving signal.

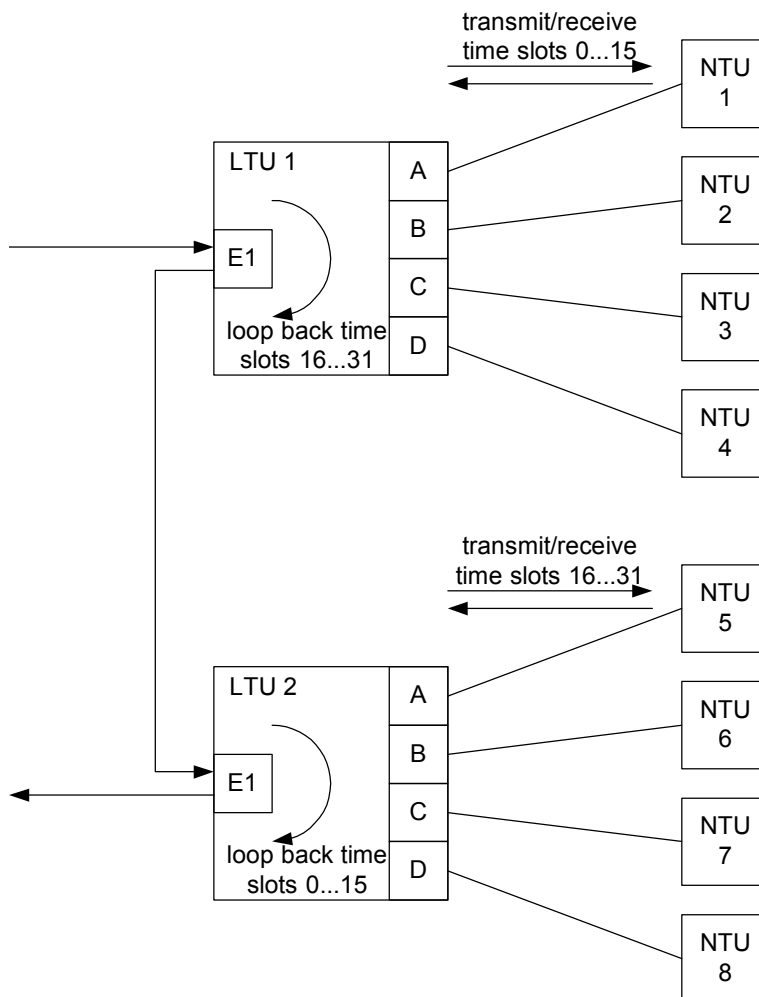

Figure 8-2: Cascading of Multipoint LTUs

Example (see Figure 8-2):

We distribute the 32 time slots of an E1 frame to eight NTUs, every NTU gets 4 time slots (256 kbit/s). NTUs 1 to 4 (connected to LTU 1) get time slots 0 ... 3, 4 ... 7, 8 ... 11, 12 ... 15 and NTUs 5 to 8 (connected to LTU 2) get time slots 16 ... 19, 20 ... 23, 24 ... 27, 28 ... 31.

LTU 1 is configured using the following commands

MP 1 AAAABBBBCCCCDDDDLLLLLLLLLLLLLLLL
MP A 1111
MP B 01111
MP C 01111
MP D 01111

which results in the following configuration:

```

-----
Multipoint Configuration
-----
TS 0 0 0 0 0 0 0 0 0 0 1 1 1 1 1 1 1 1 1 2 2 2 2 2 2 2 2 2 2 3 3
Nr 0 1 2 3 4 5 6 7 8 9 0 1 2 3 4 5 6 7 8 9 0 1 2 3 4 5 6 7 8 9 0 1

1  A A A A B B B B C C C C D D D D L L L L L L L L L L L L L L L L
2  - - - - - - - - - - - - - - - - - - - - - - - - - - - - - -

A  1 1 1 1 - - - - - - - - - - - - - - - - - - - - - - - - - - - -
B  - 1 1 1 1 - - - - - - - - - - - - - - - - - - - - - - - - - - - -
C  - 1 1 1 1 - - - - - - - - - - - - - - - - - - - - - - - - - - - -
D  - 1 1 1 1 - - - - - - - - - - - - - - - - - - - - - - - - - - - -
-----

```

and LTU 2 in the same way:

MP 1 LLLLLLLLLLLLLLLLLAAAABBBBCCCCDDDD
MP A 01111
MP B 01111
MP C 01111
MP D 01111

```

-----
Multipoint Configuration
-----
TS 0 0 0 0 0 0 0 0 0 0 1 1 1 1 1 1 1 1 1 2 2 2 2 2 2 2 2 2 2 3 3
Nr 0 1 2 3 4 5 6 7 8 9 0 1 2 3 4 5 6 7 8 9 0 1 2 3 4 5 6 7 8 9 0 1

1  L L L L L L L L L L L L L L L L A A A A B B B B C C C C D D D D
2  - - - - - - - - - - - - - - - - - - - - - - - - - - - - - -

A  - 1 1 1 1 - - - - - - - - - - - - - - - - - - - - - - - - - - - -
B  - 1 1 1 1 - - - - - - - - - - - - - - - - - - - - - - - - - - - -
C  - 1 1 1 1 - - - - - - - - - - - - - - - - - - - - - - - - - - - -
D  - 1 1 1 1 - - - - - - - - - - - - - - - - - - - - - - - - - - - -
-----

```

The E1 output of LTU 1 is connected to the E1 input of LTU 2; the E1 equipment at the LTU side is connected to the E1 input of LTU 1 and the E1 output of LTU 2.

Note that the number of time slots, which are looped back, has to be 2, 4, 8, or 16.

8.3 LEDs

The four LEDs (1..4) are used to display normal operation condition and alarm condition. Each LED can be green, amber, or red when lit according to the following table.

8.3.1 Status LEDs

<i>Status</i>	<i>LED</i>
Power failure	off
Local Hardware - / Software failure	red blinking
Normal operation	green
Non-urgent alarms (local / remote)	amber
Urgent alarms (local / remote)	red

Table 8-1: LED Indication

9 Front and Rear Panel Description

9.1 Tabletop NTU, Rear Panel

E1 120Ω

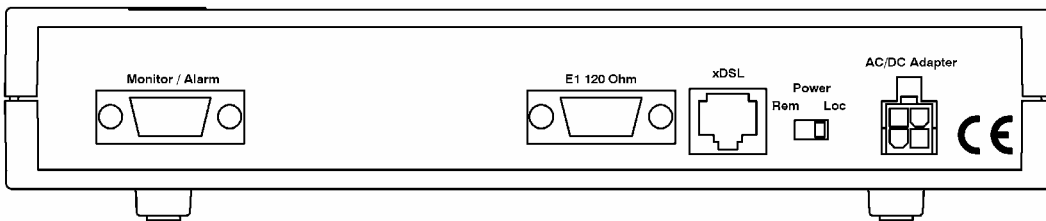

E1 75Ω

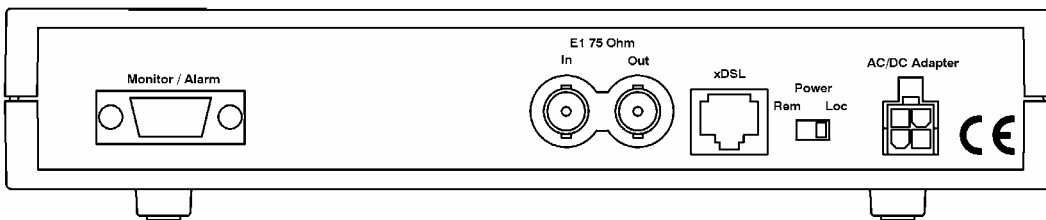

nx64kbit/s

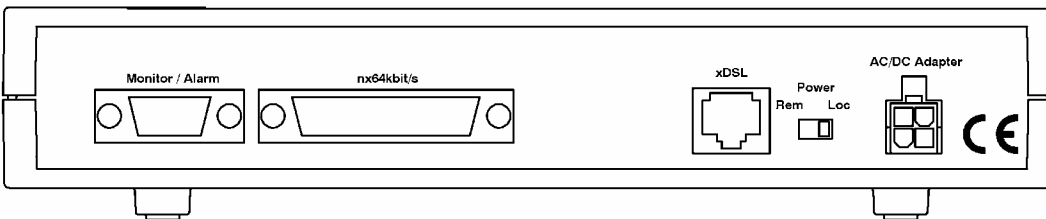

Multiservice E1 120Ω & nx64kbit/s

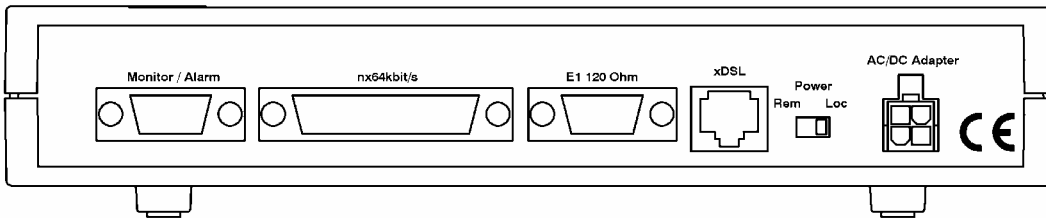

Multiservice E1 75Ω & nx64kbit/s

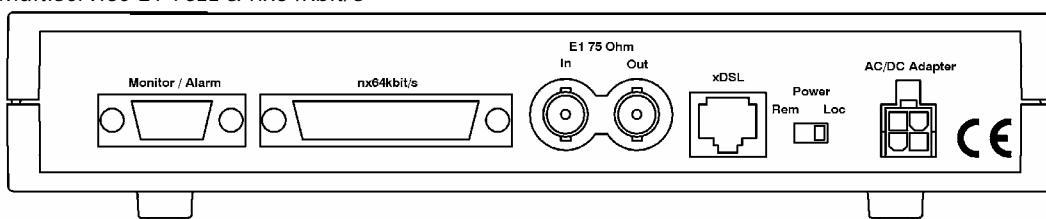

9.2 Plug-in LTU, Front Panel

Dual 2*E1 120Ω
Multipoint 2*E1 120Ω

Dual 2*E1 75Ω
Multipoint 2*E1 75Ω

Dual 2*nx64kbit/s

Multiservice
E1 120Ω &
nx64kbit/s

Multiservice
E1 75Ω &
nx64kbit/s

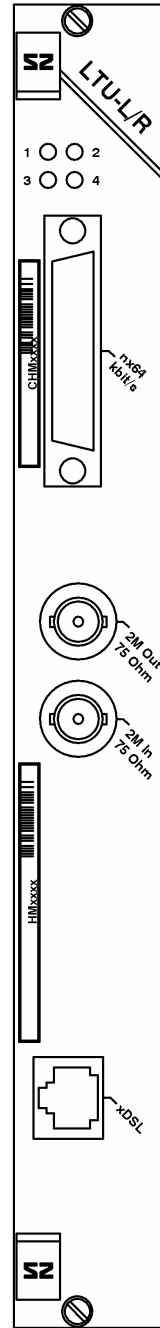
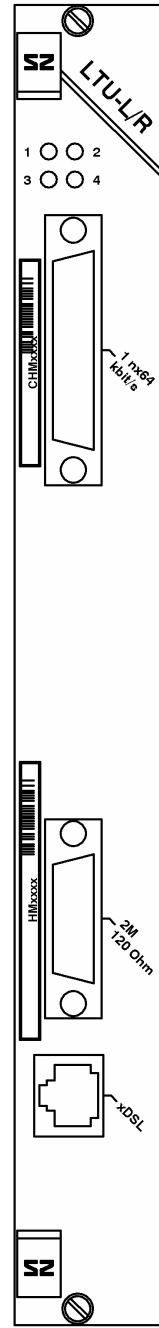
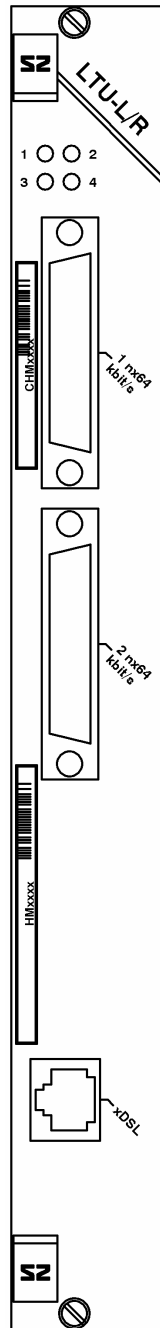
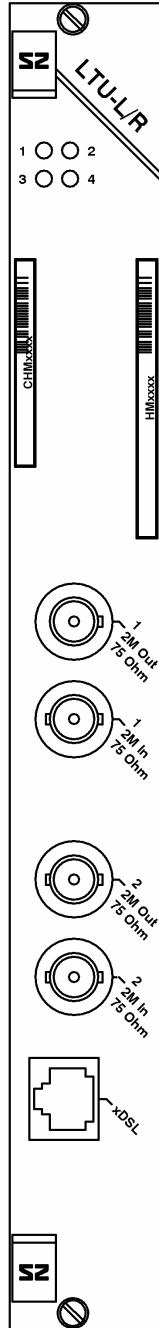
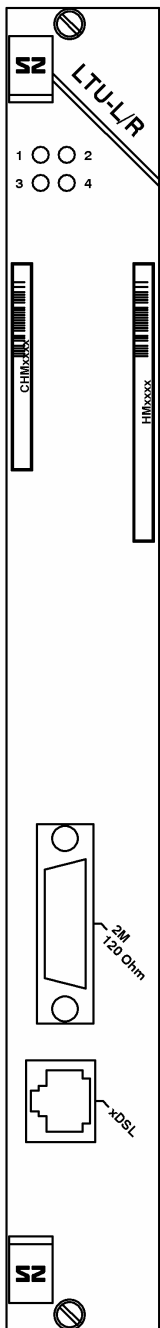

10 Connectors' Description

10.1 DSL Connector

Type: RJ45-8

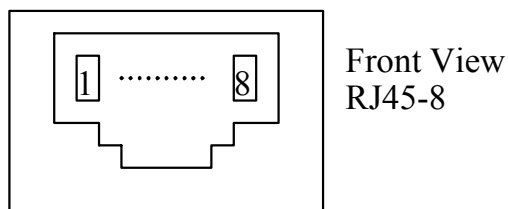

Figure 10-1: DSL Connector Backview

		NTU		LTU (Dual and Multipoint)	
Pin	Signal	Description	Signal	Description	
1	NC	-	LD.a	Loop D, tip	
2	Shield	DSL cable shield (optional)	LD.b	Loop D, ring	
3	LB.a	Loop B, tip	LB.a	Loop B, tip	
4	LA.a	Loop A, tip	LA.a	Loop A, tip	
5	LA.b	Loop A, ring	LA.b	Loop A, ring	
6	LB.b	Loop B, ring	LB.b	Loop B, ring	
7	Shield	DSL cable shield (optional)	LC.a	Loop C, tip	
8	NC	-	LC.b	Loop C, ring	

Table 10-1: DSL connector pin assignment

10.2 E1 Connector

10.2.1 Impedance 120Ω

LTU:

Type: SubD15 male (Front View)

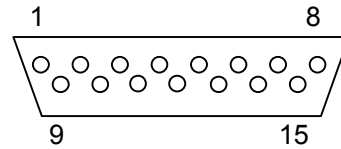

<i>Pin</i>	<i>Signal</i>	<i>Description</i>
1	RX1a	E1 120Ω Output 1 (wire A)
2	FPE	Functional Protective Earth (cable shield RX)
3	TX1a	E1 120Ω Input 1 (wire A)
4	FPE	Functional Protective Earth (cable shield TX)
5	FPE	Functional Protective Earth (cable shield RX)
6	RX2a	E1 120Ω Output 2 (wire A)
7	FPE	Functional Protective Earth (cable shield TX)
8	TX2a	E1 120Ω Input 2 (wire A)
9	RX1b	E1 120Ω Output 1 (wire B)
10	NC	-
11	TX1b	E1 120Ω Input 1 (wire B)
12	NC	-
13	RX2b	E1 120Ω Output 2 (wire B)
14	NC	-
15	TX2b	E1 120Ω Input 2 (wire B)

Table 10-2: Pin Assignment E1 120 Ohm connector

NTU:

Type: SubD9 male (Front View)

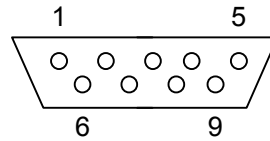

<i>Pin</i>	<i>Signal</i>	<i>Description</i>
1	RXa	E1 120Ω Output (wire A)
2	FPE	Functional Protective Earth (cable shield RX)
3	NC	-
4	FPE	Functional Protective Earth (cable shield TX)
5	TXa	E1 120Ω Input (wire A)
6	RXb	E1 120Ω Output (wire B)
7	NC	-
8	NC	-
9	TXb	E1 120Ω Input (wire B)

Table 10-3: Pin Assignment 120Ohm E1 Sub-D9 connector

10.2.2 Impedance 75Ω

Type: BNC 75Ω

10.3 nx64 kbit/s Connector

10.3.1 User Interface Type

A female SubD25 connector is used for all modes. The table below depicts the pin-out of the connector for the different modes (according to RS-530, ISO 2110) and the signal levels used for the signals.

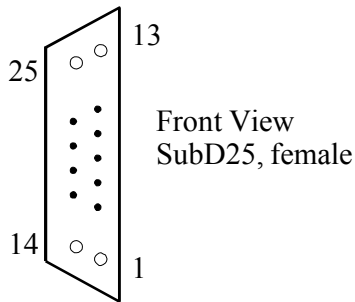

Figure 10-2: Front-view nx64 Sub-D25 connector

Pin Nr.	i/o	ITU-T Number			Signal Level		
		V.35	V.36	X.21	V.35	V.36	X.21
1		FGND	FGND	FGND			
2	i	103A	103A	TA	V.35	V.11	V.11
3	o	104A	104A	RA	V.35	V.11	V.11
4	i	105	105A	CA	V.28	V.11	V.11
5	o	106	106A	IA	V.28	V.11	V.11
6	o	107	107A		V.28	V.11	
7		102	102	G			
8	o	109	109A		V.28	V.11	
9	o	115B	115B	BB	V.35	V.11	V.11
10	o		109B			V.11	
11	i	113B	113B	XB	V.35	V.11	V.11
12	o	114B	114B	SB	V.35	V.11	V.11
13	o		106B	IB		V.11	V.11
14	i	103B	103B	TB	V.35	V.11	V.11
15	o	114A	114A	SA	V.35	V.11	V.11
16	o	104B	104B	RB	V.35	V.11	V.11
17	o	115A	115A	BA	V.35	V.11	V.11
18	i	141	141		V.28	V.10	
19	i		105B	CB		V.11	V.11
20	i	108/2	108/2A	BIA	V.28	V.11	V.11
21	i	140	140		V.28	V.10	
22	o		107B			V.11	
23	i		108/2B	BIB		V.11	V.11
24	i	113A	113A	XA	V.35	V.11	V.11
25	o	142	142		V.28	V.10	

Table 10-4: Pin assignment nx64 Sub-D25 connector

The ITU-T Numbers are according to ITU-T V.24 (V.35, V.36) and ITU-T X.24 (X.21):

<i>ITU-T Number</i>	<i>Description</i>	<i>From DCE</i>	<i>To DCE</i>
102, G, SGND	Signal Ground		
103, T	Transmitted data		x
104, R	Received data	x	
105, C	Request to send		x
106, I	Clear to send	x	
107	Data set ready	x	
108/2	Data terminal ready		x
109	Data channel received line signal detector	x	
113, X	Co-directional transmitting clock, the transmitted data will be sampled with the rising edge.		x
114	Contra-directional transmitting clock, the transmitted data will be sampled with the rising edge.	x	
115, S	Receive clock, the received data will be sampled with the rising edge.	x	
140	Remote loopback		x
141	Local loopback		x
142	Test Mode	x	
B	Byte timing, OFF during the first half of the last bit of a byte.	x	
BI	Byte timing input (proprietary designation)		x

Table 10-5: Signal Description of nx64 connector

The interface is of type DCE, use the appropriate adapter cable for a DTE connector or the standard connectors ISO 2593 for V.35, ISO 4902 for V.36, ISO 4903 for X.21.

10.3.2 nx64 kbit/s Cables

10.3.2.1 V.35 DTE Cable

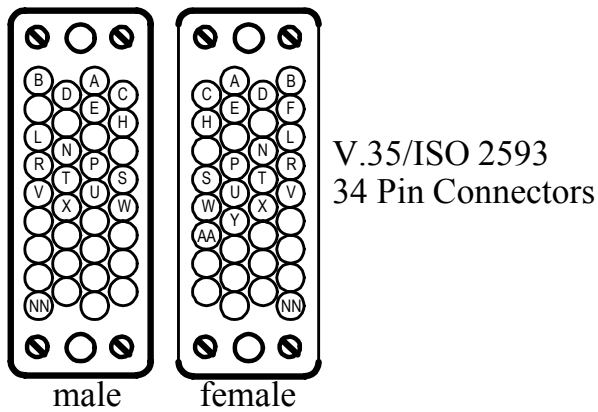

Connector Type: 34 pin (ISO 2593), female

ITU-T Number	Pin Assignment 34 pin female (a/b)	Pin Assignment 25 pin male (a/b)
FGND	A	1
SGND	B	7
103	P/S	2/14
104	R/T	3/16
105	C	4
106	D	5
107	E	6
108	H	20
109	F	8
113	U/W	24/11
114	Y/AA	15/12
115	V/X	17/9
140	N	21
141	L	18
142	NN	25

10.3.2.2 V.35 DCE Cable

Connector Type: 34 pin (ISO 2593), male

ITU-T Number	Pin Assignment 34 pin male (a/b)	Pin Assignment 25 pin male (a/b)
FGND	A	1
SGND	B	7
103	P/S	3/16
104	R/T	2/14
105	C	5
106	D	4
107	E	20
108	H	6
109	-	-
113	U/W	17/9
114	-	-
115	V/X	24/11
140	N	25
141	L	25
142	NN	18

10.3.2.3 V.36 DTE Cable

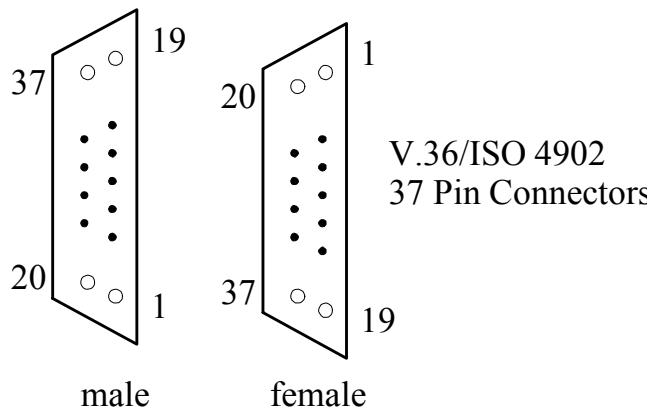

Connector Type: 37 pin (ISO 4902), female

ITU-T Number	Pin Assignment 37 pin female (a/b)	Pin Assignment 25 pin male (a/b)
FGND	1	1
SGND	19	7
SGND(a)	37	7
SGND(b)	20	7
103	4/22	2/14
104	6/24	3/16
105	7/25	4/19
106	9/27	5/13
107	11/29	6/22
108	12/30	20/23
109	13/31	8/10
113	17/35	24/11
114	5/23	15/12
115	8/26	17/9
140	14	21
141	10	18
142	18	25

10.3.2.4 V.36 DCE Cable

Connector Type: 37 pin (ISO 4902), male

ITU-T Number	Pin Assignment 37 pin male (a/b)	Pin Assignment 25 pin male (a/b)
FGND	1	1
SGND	19	7
SGND(a)	37	7
SGND(b)	20	7
103	4/22	3/16
104	6/24	2/14
105	7/25	5/13
106	9/27	4/19
107	11/29	20/23
108	12/30	6/22
109	-	-
113	17/35	17/9
114	-	-
115	8/26	24/11
140	14	25
141	10	25
142	18	18

10.3.2.5 X.21 DTE Cable

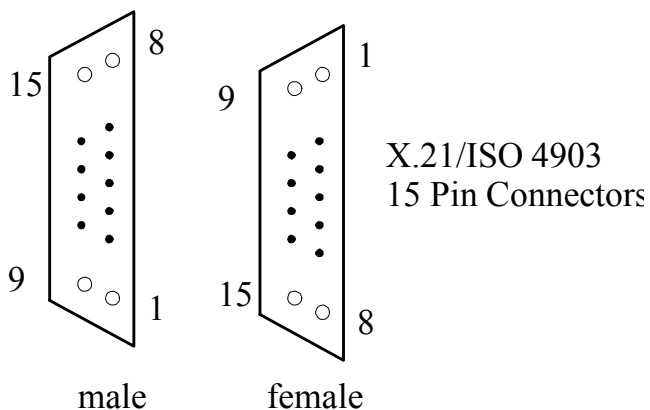

Connector Type: 15 pin (ISO 4903), female

ITU-T Number	Pin Assignment 15 pin female (a/b)	Pin Assignment 25 pin male (a/b)
FGND	1	1
G	8	7
S	6/13	15/12
R	4/11	3/16
T	2/9	2/14
C	3/10	4/19
I	5/12	5/13
B	7/14	17/9 ¹⁾
BI	(7/14) ¹⁾	20/23 ¹⁾

Note: Pins 17-20 and 9-23 have to be connected inside the 25-pin connector.

Alternatively, when the co-directional clock X is used, but no byte clock, this cable can be used:

ITU-T Number	Pin Assignment 15 pin female (a/b)	Pin Assignment 25 pin male (a/b)
FGND	1	1
G	8	7
S	6/13	15/12
R	4/11	3/16
T	2/9	2/14
C	3/10	4/19
I	5/12	5/13
X	7/14	24/11

10.3.2.6 X.21 DCE Cable

Connector Type: 15 pin (ISO 4903), male

ITU-T Number	Pin Assignment 15 pin male (a/b)	Pin Assignment 25 pin male (a/b)
FGND	1	1
G	8	7
S	6/13	24/11
R	4/11	2/14
T	2/9	3/16
C	3/10	5/13
I	5/12	4/19
B	7/14	20/23

Alternatively, when the co-directional clock X is used, but no byte clock, this cable can be used:

ITU-T Number	Pin Assignment 15 pin female (a/b)	Pin Assignment 25 pin male (a/b)
FGND	1	1
G	8	7
S	6/13	24/11
R	4/11	2/14
T	2/9	3/16
C	3/10	5/13
I	5/12	4/19
X	7/14	15/12

10.4 Monitor Connector (NTU)

Type: SubD9 female (Front View)

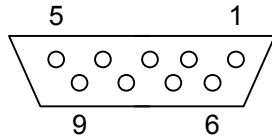

<i>Pin</i>	<i>Signal</i>	<i>Description</i>
1	SGND	RS-232 Signal Ground
2	TXD	RS-232 Transmit Data
3	RXD	RS-232 Receive Data
4	ALACOM	Common contact of Alarm relay
5	SGND	RS-232 Signal Ground
6	DA_NC	Urgent-Alarm contact, normally closed
7	DA_NO / CTS	Urgent-Alarm contact, normally open / RS-232 Clear to send
8	ND_NC / RTS	Non Urgent-Alarm contact, normally closed / RS-232 Ready to send
9	ND_NO	Non Urgent-Alarm contact, normally open

10.5 48V_{DC} Power Connector (NTU)

Type: Molex Minifit Junior, safety approved connector to the mains adapter with snap-in characteristic.

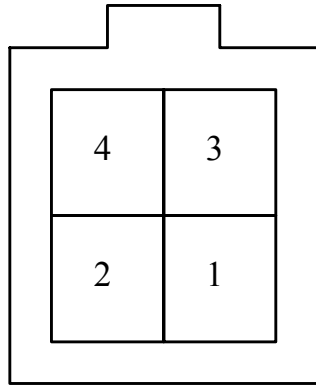

Frontview
Molex-Type Power Connector

<i>Pin</i>	<i>Signal</i>	<i>Description</i>
1	-PWR	Negative power supply terminal for mains adapter
2	PROT	Connected to the center taps of the gas absorbers at the DSL line input
3	NC	Not connected
4	+PWR	Positive power supply terminal for mains adapter

11 Technical Specifications

11.1 Interfaces

11.1.1 DSL Line Interface

Norm referred:	ETSI TS 101 524, ITU-T G.991.2 Annex B
Number of Pairs:	1, 2 or 4
Line Rate per Pair:	200-2320kbit/s \pm 32ppm
Line Code:	Trellis-coded PAM16
Nominal Line Impedance:	135 Ω
Transmit Power @ 135 Ω :	According to TS 101 524
Overvoltage Protection:	LTU: ITU-T K.20: 2000 (K.44:2000) NTU: ITU-T K.21:2000 (K.44:2000)
Connector Type:	RJ-45, 8 pin

11.1.2 User Interface

E1:

Norm referred:	ITU-T G.703 / G.704
Bit Rate:	2048kbit/s \pm 50ppm
Line Code:	HDB3
Framing:	ITU-T G.704 / transparent
Input Impedance:	120 Ω 75 Ω
Signal Amplitude:	\pm 3.00V @ 120 Ω \pm 2.37V @ 75 Ω
Jitter Performance:	According to ITU-T G.823
ESD - Protection:	8kV (Air discharge)
Connector Type:	LTU: SubD15 male 120 Ω or BNC 75 Ω NTU: SubD9 female 120 Ω or BNC 75 Ω

PRA:

Norm referred:	ETS 300 233, ETS 300 011, ETS 300 046
----------------	---------------------------------------

nx64 kbit/s:

	V.35	V.36	X.21
Bit Rate:	nx64 kbit/s (n=0..72), (n=0..96, in 3p and 4p mode)		
Signal Levels:			
Data Lines:	ITU-T V.35	ITU-T V.11	ITU-T V.11
Clock Lines:	ITU-T V.35	ITU-T V.11	ITU-T V.11
Control Lines:	ITU-T V.28	ITU-T V.11/V.10	ITU-T V.11
ESD-Protection:	8kV (Air discharge)		
Connector Type HDSL:	SubD25 (ISO 2110), female	SubD25 (RS 530), female	SubD25 female
Connector Type Cable:	34 pin (ISO 2593)	37 pin (ISO 4902)	15 pin (ISO 4903)

11.1.3 Monitor Interface

Signal Level:	RS-232
Data Rate:	9600 Baud, Asynchronous
Protocol:	8 Bit, No Parity, 1 Stop Bit No Linefeed with Carriage Return XON/XOFF enabled
Connector Type:	SubD9 female

11.2 Power Supply

Power consumption depends on operation mode 1p/2p, line rate, data rate of UIF and transceiver assembly.

11.2.1 LTU

Supply Voltage:	-40.5V _{DC} .. -72V _{DC}
-----------------	--

Power consumption (dependent on line rate and remote powering current):

	Remote Power OFF	Remote Power ON <i>Additional Power Consumption</i>					
		0mA		10mA		50mA	
		total	local	total	local	total	local
SZ.866.V711, dual link 2p	6.6/8.5	0.8/1.2	0.8/1.2	5.8/6.1	1.2/1.7	25.6/26	4.0/4.4
SZ.866.V511, dual link 1p	3.8/5.4	1.0/1.2	1.0/1.2	3.4/3.5	1.2/1.3	13.1/13.4	2.3/2.6
SZ.866.V788, dual link 2p	6.6/9.1	0.8/1.2	0.8/1.2	5.8/6.1	1.2/1.7	25.6/26	4.0/4.4

Note: Watson 5 LTUs are supposed to be used with the subrack SZ.379.V3W \underline{D} A having a 16A fuse.

11.2.2 NTU

Power consumption (dependent on line rate):

	Local Power Supply	Remote Power Supply
Supply Voltage	-40.5V _{DC} .. -72V _{DC}	-112V _{DC} .. -65V _{DC} at NTU DSL-Connector
SZ.886.V410, 2p	3.9 - 4.9	3.7 - 4.6
SZ.886.V480, 2p (up to 4608kbit/s)	4.0 - 6.0	3.7 - 5.7
SZ.886.V310, 1p	2.8 - 3.7	2.6 - 3.4
SZ.886.V380, 1p	2.9 - 3.6	2.8 - 3.5
SZ.886.V418, 2p (up to 4608kbit/s)	4.4 - 6.3	4.0 - 6.0

11.3 Environment

11.3.1 Climatic Conditions

Storage:	ETS 300 019-1-1 Class 1.2	-25°C ... +55°C
Transportation:	ETS 300 019-1-2 Class 2.3	-40°C ... +70°C
Operation:	ETS 300 019-1-3 Class 3.2	-5°C ... +45°C

11.3.2 Safety

According to EN 60950:2000 (IEC60950:1999)

11.3.3 EMC

According to EN 300386:2000

11.4 Physical Dimensions

11.4.1 LTU

19" Plug-in unit: height: 259mm (6 HE), width: 30mm

PCB dimensions: height: 233.35mm, length: 220mm

11.4.2 NTU

Tabletop unit: width 220mm, depth 195mm, height 43mm

12 Firmware Download

12.1 Download Procedure

Application firmware download to LTU and NTU is carried out with a special Flashloader program running on a PC.

During a remote download to the NTU via the LTU, the DSL link is not available for payload data transfer. The DSL link is transparent forward between local V.24 and DSL in this case.

The loader program on the remote modem is started in the RAM (it cannot re-establish a DSL link), it communicates over DSL timeslots and saves the new program in a backup area of the flash memory on the NTU (secondary image area).

Note: A DSL link disconnection or 8 failed retries during a remote download will cause reset and a restart of the old application program at the remote site.

After successfully saving the new program, an indication flag in the old application FW of the remote modem is set to status "valid but old". Automatic reset of the remote modem will then copy the new program from secondary to primary image area of the flash memory.

The remote downloading process uses an end-to-end flow control. Bit failures will cause a re-sending of the last data package instead of re-starting the download procedure.

The application FW file includes a program type identifier. This identifier can be displayed by the File Information command of the Flashloader program. The type identifier is evaluated by the loader program on the target device as well. It checks if the firmware is allowed to run on the target HW. If a wrong program is tried to be loaded, the downloading process will fail and gives an error messages in the Flashloader program. The program type identifier is a 32 bit set, that describes product and device type, e.g.

Product: Watson4, Watson5, Pegasus, etc.

Device: NTU, LTU_SINGLE, LTU_DUAL, REGENERATOR, etc.

The operator of the Flashloader program is responsible for choosing the right application program file and version, as well as the correct addresses of the target devices. E.g. loading Watson5 dual LTU application on a Watson4 dual LTU device will fail and leave the Watson4 dual LTU device retrying to load the right program.

Both the Flashloader program and the application program do not perform a program version check.

12.2 Download transport via ACU

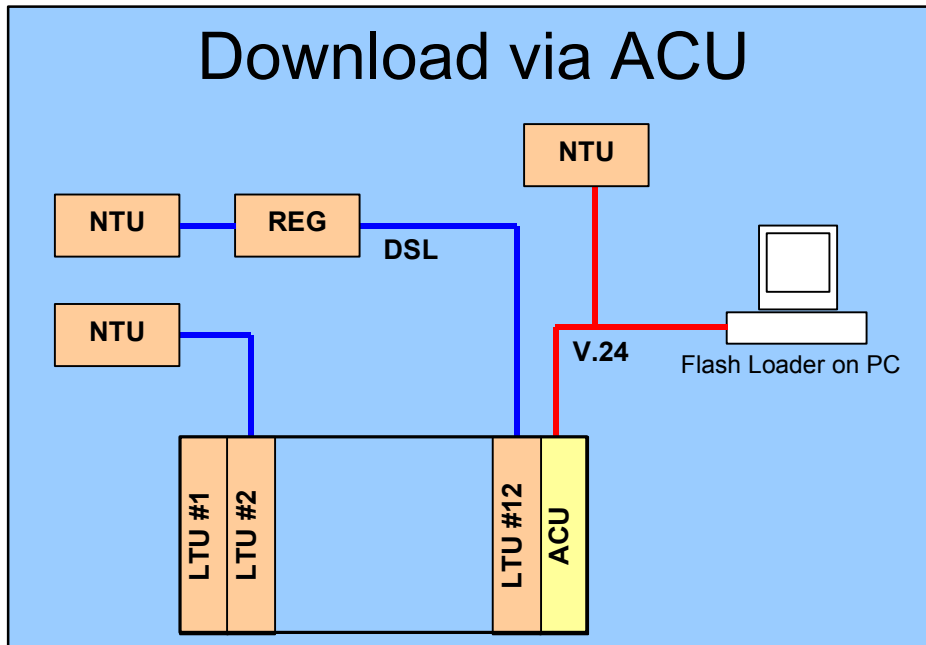

Download possibilities:

Firmware download to NTU over

- V.24
- V.24 and DSL link (remote firmware download)

Firmware download to LTU/REG over

- V.24 via ACU2R/ACU48R

Setting the ACU in transparent mode allows program download over ACU's V.24 Interface.

Local download speed: DSL monitor uses the V.24 interface in 9600bit/s. Program download of one modem over LTU rack's V.24 using different baud rate (e.g. 19200), can disturb normal operation of other modems on the same rack.

12.3 Download transport via CMU

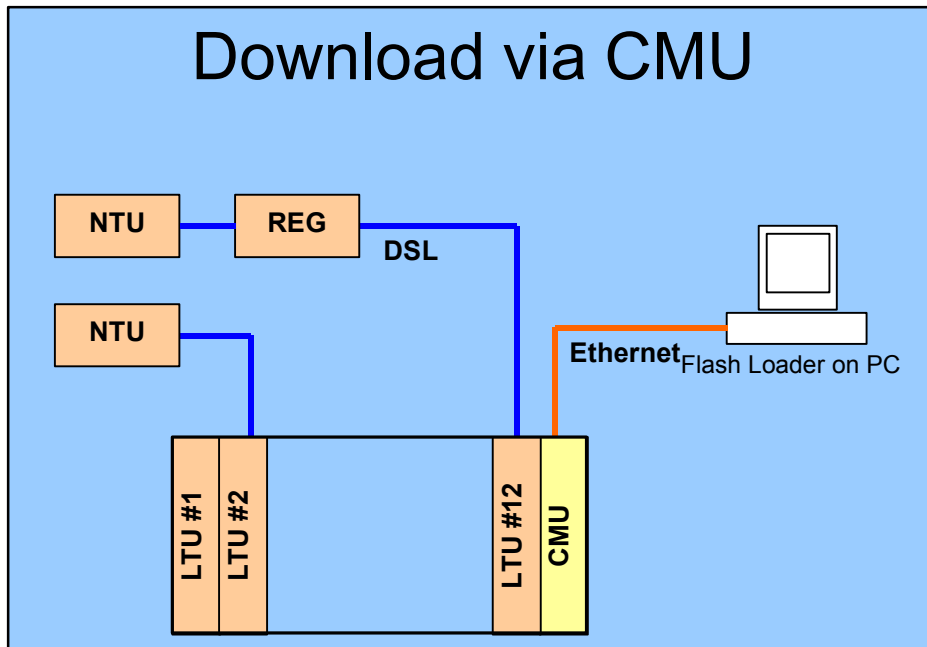

Download possibilities:

Firmware download to NTU over

- Ethernet and DSL link via CMU

Firmware download to LTU/REG over

- Ethernet via CMU

Download over RS485 bus (CMU Interface) is not supported yet.

12.4 Download transport via Modem Chain

Download over a DSL chain as shown below will be possible when a V.24 Interface connects NTU #1 and NTU #2.

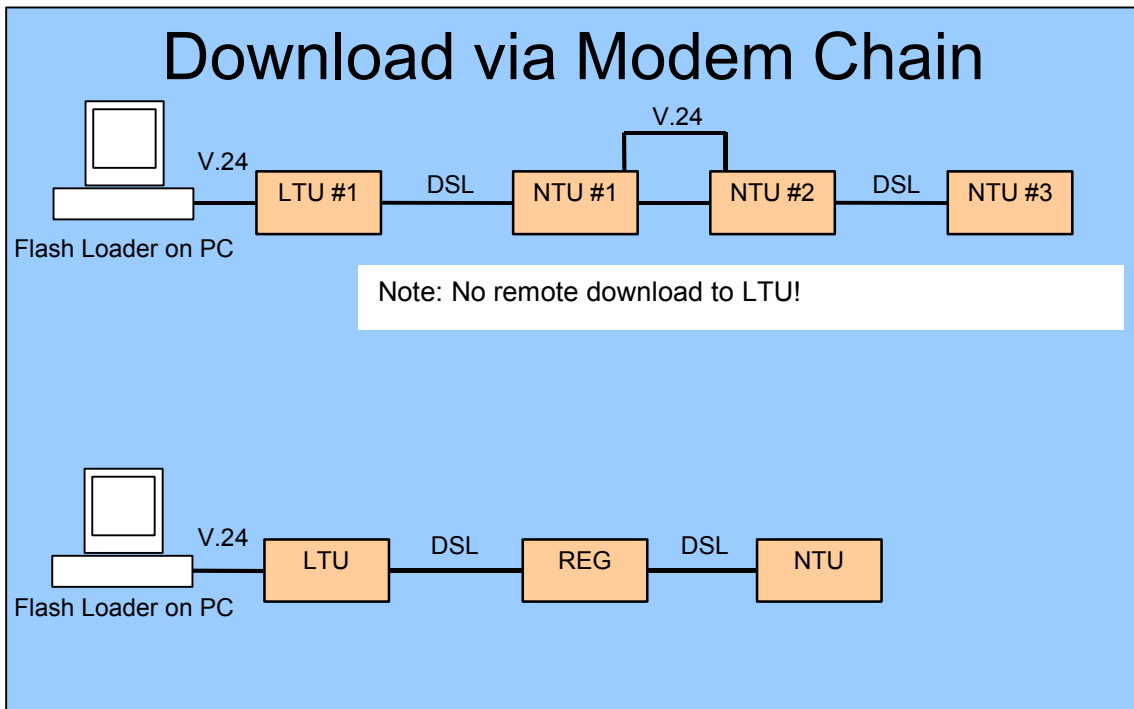

Note: Firmware can only be downloaded to NTUs within a Modem chain!

12.5 Remote Firmware Download Procedure

To remotely download a new firmware to the NTU via LTU, proceed as follows.

1. Start Flash Loader program (loader.exe) on your PC and change *Setting* as follows (see also screen shots on the next page):
2. 'Set File Path' to the application program (.bin file) you want to download to the NTU
3. 'Set Loader Communication' to operate with end-to-end flow control (disable XON/XOFF, enable Flow Control option).
4. 'Set Erase Commands' as shown below (change % LTU address according to slot position, if required).
5. Make sure that the link to the NTU is running.
6. Start *Action* 'Erase and prepare Loading'.

7. On the LTU, the Status LEDs of the addressed system will blink amber when ready for download, and green when download is in progress
8. On the NTU, the Status LED will blink red when the Flash Memory's secondary image is being erased, amber when ready for download, and green if download is in progress
9. If download completes successfully, the NTU will break the link, copy the new program from the secondary to the primary image of the Flash Memory and restart the link with the new application FW stored in the primary image.
10. If download fails (e.g. link disconnection), the LTU will return to normal operation and the NTU will restart with the old application program.

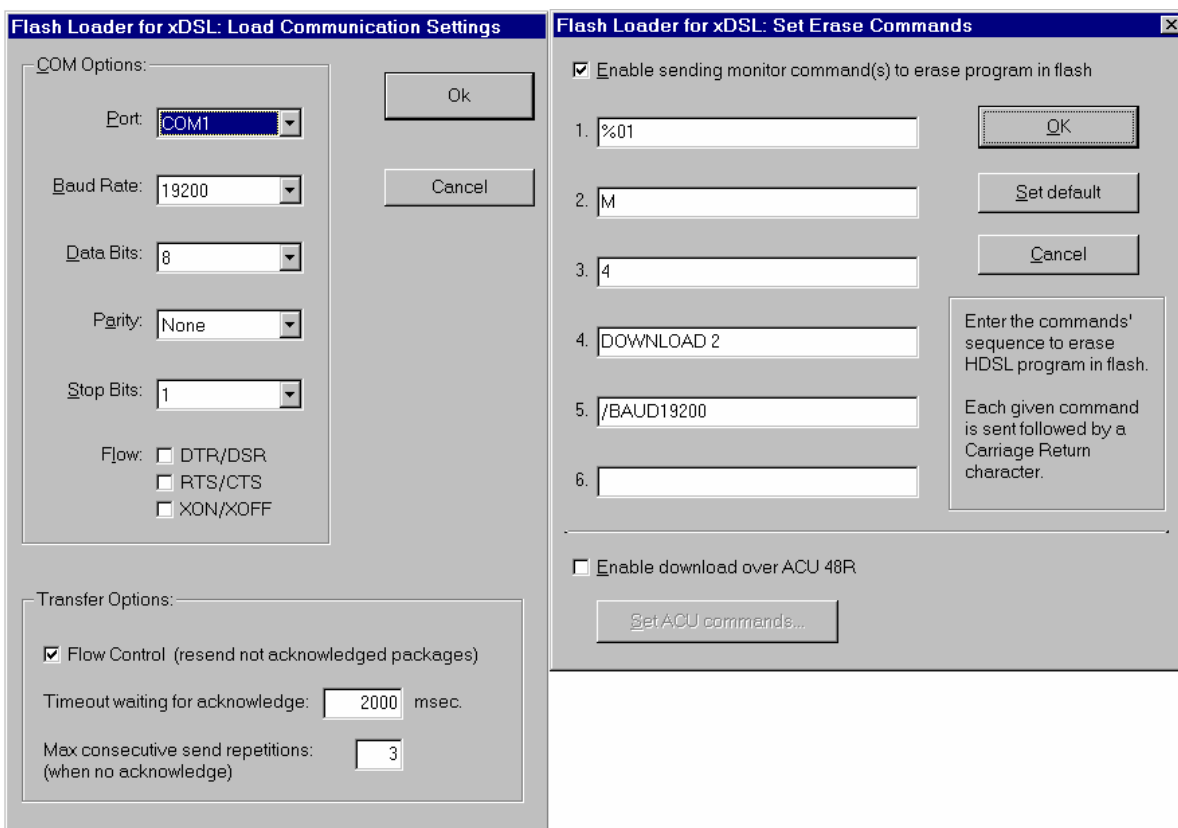

13 Diagnostics and Troubleshooting

13.1 Test Loops

Standard Test Loops

The test loops can be activated via the monitor interface for both the master and the slave side. However, only one test loop can be activated at any one time. Activation of a further test loop will deactivate the previous loop. A system reset will deactivate any pending test loop.

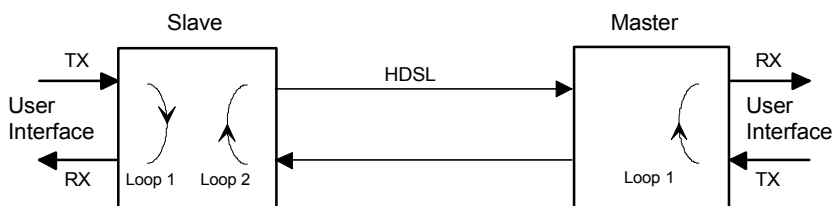

Figure 13-1: Standard Test Loops

Notes: On the slave side, Loop 1 can only be activated locally, while Loop 2 can only be activated remotely by the master. Both the "Status Local" LED on the slave and the "Status Remote" LED on the master will be lit amber when a loopback is active.

On the master side, Loop 1 can only be activated locally. Activating Loop 2 turns on Loop 2 at the slave station. The "Status Local" LED will be lit amber when Loop 1 is active.

Analog Loopback

To test the DSL UNIT itself, the Analog Loopback can be used. To perform this test, the DSL cable has to be disconnected from the unit, which must be configured as master. After that the test can be activated with the appropriate monitor command (see chapter "Monitor").

With activated Analog Loopback, the DSL transceiver receives the signal of its own transmitter due to the impedance mismatch in the DSL line transformer. All data of the user interface is looped back according to the interface settings.

No other test loop can be activated during Analog Loopback. STOPAL command, system reset or power-up deactivating the Analog Loopback..

If activated, the Analog Loopback sets non-urgent alarms in status off.

13.2 Hints for Troubleshooting

13.2.1 Problems

Problem

No response from the modem

To do:

- Please check your physical serial connection.
- Does the PC/cable combination work on other modems?
- Is it the correct cable (see manual section "Cables")?
- Is the cable grounding correctly connected (floating ground)?
Check cable.
- Please check your baud rate, COM1, COM2, etc configuration on the PC (see chapter "Monitor").
- Try typing <Control-Q> which is XON and <ECHO>, (to re-enable communication to LTUs occasionally left in XOFF state)
- Try selecting the modem using <%n>, n being modem address. (See chapter "Monitor").

Strange signs are received in response from the modem.

- Check baud rate of PC
- Try typing <Control-Q> which is X-on and <ECHO>

Problems with E1 clock (frequency, drift, slips):

- Check configuration: Do not configure the E1 interfaces at both ends to use the receive clock as transmit clock except if one DSL equipment is an LTU using the "External Clock" option. Otherwise there will be no defined clock.

No startup

- If both system units are configured as master or as slave, no start-up will occur. To identify the master unit, check if both LED's are lit ,ON' The slave has only the local LED turned on.
- Check that you use twisted pair cables till to the end of DSL RJ-45 connector. Do not use other cable types as twisted pairs.

13.2.2 Initialization Errors

At system startup, various hardware selftests are performed. If any initialization error occurs, the startup procedure will be aborted and the monitor will display an initialization error code in hexadecimal representation. The table below lists the possible initialization errors and their corresponding error code word indicating the fault of hardware.

Error Code	Error Variable	Initialization Error
0x01	RAM_ERROR	Microcontroller RAM test failure
0x02	EEPROM_ERROR	EEPROM test failure
0x04	XDSL_ERROR	Framer initialization failure
0x08	TCVR_A_ERROR	DSL transceiver failure (Loop A)
0x10	TCVR_B_ERROR	DSL transceiver failure (Loop B)
0x1000	TCVR_C_ERROR	DSL transceiver failure (Loop C)
0x2000	TCVR_D_ERROR	DSL transceiver failure (Loop D)
0x40	NX64_ERROR	Nx64 interface initialization failure
0x80	ETHERNET_ERROR	Ethernet interface initialization failure
0x100	CEPT_ERROR	E1 interface initialization failure
0x8000	SW_PROTECT_ERROR	Software Copyright Protection Error

14 Appendix

14.1 Abbreviations

<i>ACU</i>	Alarm Control Unit
<i>CAP</i>	Carrierless Amplitude Phase Modulation
<i>ITU</i>	International Telecommunication Union
<i>CCS</i>	Common Channel Signaling
<i>CMU</i>	Control and Management Unit
<i>CRC</i>	Cyclic Redundancy Check
<i>DSL</i>	Digital Subscriber Loop
<i>E1</i>	ITU-T G.703 User Interface at 2048 kbit/s
<i>ET</i>	Exchange Termination
<i>EOC</i>	Embedded Operations Channel
<i>frE1</i>	Fractional E1
<i>ISDN</i>	Integrated Services Digital Network
<i>ITU-T</i>	International Telecommunication Union
<i>LT</i>	Line Termination
<i>LTU</i>	Line Termination Unit
<i>NC</i>	Not Connected
<i>NEXT</i>	Near End Cross Talk
<i>NM</i>	Noise Margin
<i>NT</i>	Network Termination
<i>NTU</i>	Network Termination Unit
<i>PDH</i>	Plesiochronous Digital Hierarchy
<i>PRA</i>	Primary Rate Access
<i>PSD</i>	Power Spectral Density

<i>Rx</i>	Receive
<i>SDH</i>	Synchronous Digital Hierarchy
<i>SDSL</i>	Single Pair High Bit Rate DSL acc. to ETSI
<i>SHDSL</i>	Single Pair High Speed DSL acc. to ITU-T
<i>SMF</i>	Sub-Multiframe
<i>SNMP</i>	Simple Network Management Protocol
<i>TE</i>	Terminal Equipment
<i>TMN</i>	Telecommunication Management Network
<i>Tx</i>	Transmit
<i>UIF</i>	User Interface
<i>UTP</i>	Unshielded Twisted Pair
<i>XVR</i>	Transceiver

14.2 Referenced Documents

- [1] EN 300 386, "Electromagnetic compatibility and radio spectrum matters (ERM); Telecommunication network equipment; Electro-Magnetic Compatibility (EMC) requirements".
- [2] EN 60950, IEC60950, "Safety of Information Technology Equipment Including Electrical Business Equipment"
- [3] ETS 300 011, "Integrated Services Digital Network (ISDN); Primary rate user-network interface. Layer 1 specification and test principles"
- [4] ETS 300 019, "Equipment Engineering; Environmental Conditions and Environmental Tests for Telecommunications Equipment"
- [5] ETS 300 046, "Integrated Services Digital Network (ISDN); Primary rate access - safety and protection"
- [6] ETS 300 233, "Integrated Services Digital Network (ISDN); Access digital section for ISDN primary rate"
- [7] ETSI TS 101 524, "Transmission and Multiplexing (TM); Symmetric single pair high bit-rate Digital Subscriber Line (SDSL) transmission system on metallic local lines"
- [8] ITU-T G.991.2, "Single-pair high-speed Digital Subscriber Line (SHDSL) transceivers"
- [9] ITU-T G.703, "Physical/Electrical Characteristics of Hierarchical Digital Interfaces"
- [10] ITU-T G.704, "Synchronous Frame Structures Used at Primary and Secondary Hierarchical Levels"
- [11] ITU-T G.821, "Error Performance of an International Digital Connection Forming Part of an Integrated Services Digital Network"
- [12] ITU-T G.823, "The Control of Jitter and Wander within Digital Networks Which Are Based on the 2048 kbit/s Hierarchy"
- [13] ITU-T G.826, "Error Performance Parameters and Objectives for International, Constant Bit Rate Digital Paths at or above the Primary Rate"
- [14] ITU-T G.962, "Access Digital Section for ISDN Primary Rate Access at 2048 kbit/s"
- [15] ITU-T I.604, "Application of Maintenance Principles to ISDN Primary Rate Accesses"
- [1] ITU-T K.20, "Resistibility of telecommunication equipment installed in a telecommunications centre to overvoltages and overcurrents".
- [2] ITU-T K.21, "Resistibility subscriber's terminal to overvoltages and overcurrents".
- [3] ITU-T K.21, "Resistibility of telecommunication equipment installed customers premises to overvoltages and overcurrents".
- [4] ITU-T K.44, "Resistibility tests for telecommunication equipment exposed to overvoltages and overcurrents".
- [5] ITU-T V.10, "Electrical Characteristics for Unbalanced Double-Current Interchange Circuits Operating at Data Signaling Rates Nominally up to 100 kbit/s"

- [6] ITU-T V.11, "Electrical Characteristics for Balanced Double-Current Interchange Circuits Operating at Data Signaling Rates up to 10 Mbit/s"
- [7] ITU-T V.24, "List of Definitions for Interchange Circuits between Data Terminal Equipment (DTE) and Data Circuit-Terminating Equipment (DCE)"
- [8] ITU-T V.28, "Electrical Characteristics for Unbalanced Double-Current Interchange Circuits"
- [9] ITU-T V.35, "Data Transmission at 48 kbit/s Using 60-108 kHz Group Band Circuits"
- [10] ITU-T V.36, "Modems for Synchronous Data Transmission Using 60-108 kHz Group Band Circuits"
- [11] ITU-T V.54, "Loop Test Devices for Modems"
- [12] ITU-T X.21, "Interface between Data Terminal Equipment and Data Circuit-Terminating Equipment for Synchronous Operation on Public Data Networks"
- [13] ITU-T X.24, "List of Definitions for Interchange Circuits between Data Terminal Equipment (DTE) and Data Circuit-Terminating Equipment (DCE) on Public Data Networks"
- [14] ISO 2593, "Connector pin allocations for use with high-speed data terminal equipment", 1973.
- [15] ISO 2110, "Data communication - 25-pin DTE/DCE interface connector and pin assignments", 1980.
- [16] ISO 4902, "Data communication - 37-pin and 9-pin DTE/DCE interface connectors and pin assignments", 1980.
- [17] ISO 4903, "Data communication - 15-pin DTE/DCE interface connector and pin assignments", 1980.